

Designated client product

This product will be discontinued its production in the near term.
And it is provided for customers currently in use only, with a time limit.
It can not be available for your new project. Please select other new or existing products.

For more information, please contact our sales office in your region.

New Japan Radio Co.,Ltd.

<http://www.njr.com/>



AUDIO PROCESOR with SRS&BBE&ealaBASS

■ GENERAL DESCRIPTION

NJW1177 is a sound processor includes all of the functions required to process the audio signal for TV, such as volume, balance, mute, tone control, AGC functions. And also It performs NJRC original dynamic bass boost technology "ealaBASS" provides graceful bass sound with low distortion. All of internal states and variables are controlled by I²C BUS interface. In addition to SRS and BBE, since NJW1177 builds in ealaBASS, it reproduces clearly, natural and rich bass sound

■ PACKAGE OUTLINE



NJW1177V

■ FEATURES

- Operating Voltage +7.5 to +13V
- I²C BUS interface
- BBE Sound Enhancement (Low Boost and High Boost: 15dB max.)
- SRS 3D Stereo
- eala
- eala BASS (Dynamic Bass Boost)
- Simulated Stereo
- AGC Circuit
- Low Noise VCA
- Bi-CMOS technology
- Package Outline SSOP44

■ BLOCK DIAGRAM

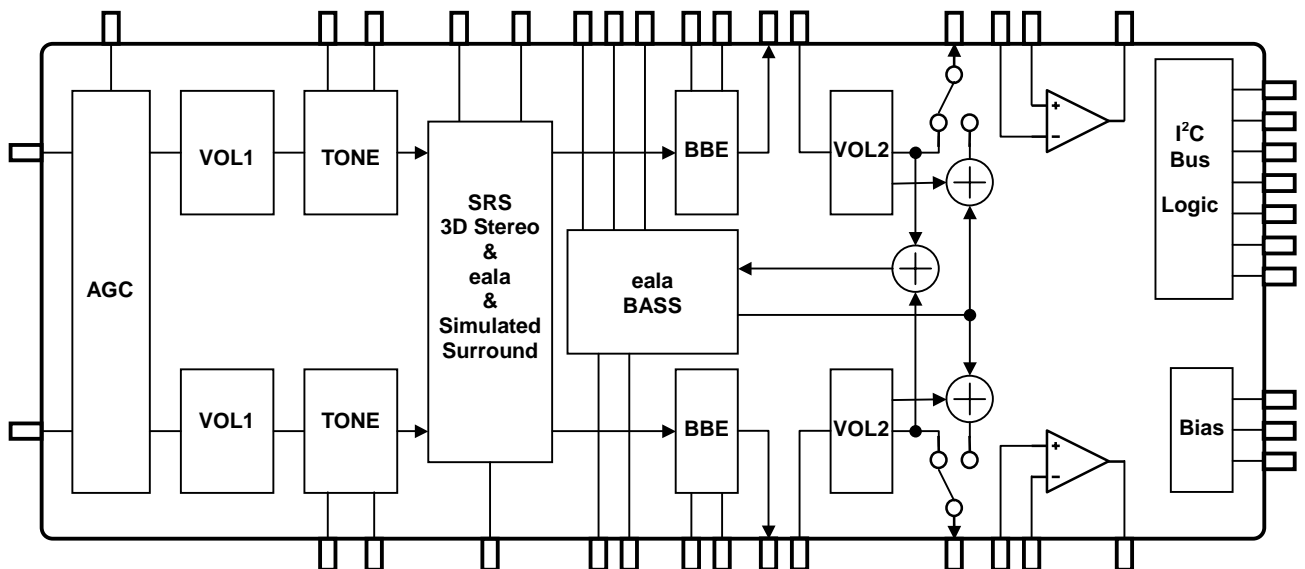

■ PIN ASSIGNMENT

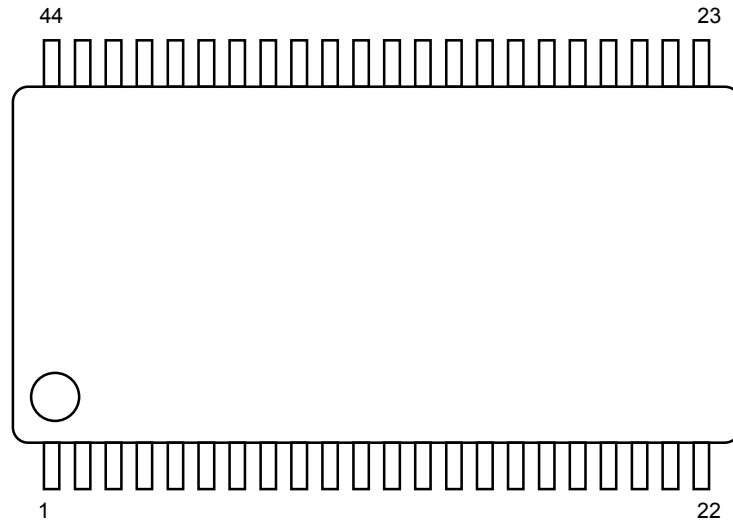

No	Symbol	Function	No	Symbol	Function
1	INa	Ach Input	23	V+	Power Supply Input
2	SURROUND FIL	Surround Filter Capacitor	24	AUX1	Auxiliary Output 1
3	TONE-Ha	Ach TONE Treble Filter Capacitor	25	AUX0	Auxiliary Output 0
4	TONE-La	Ach TONE Bass Filter Capacitor	26	VREF	Reference Voltage Stabilizing Capacitor
5	BBEHa	Ach BBE Filter1 (Process)	27	CTL	Pop Noise Capacitor for TONE Bass
6	BBELa	Ach BBE Filter2 (Lo Contour)	28	CTH	Pop Noise Capacitor for TONE Treble
7	SENDa	Ach output for the other accessories	29	CBH	Pop Noise Capacitor for BBE
8	RETURNa	Ach input from the other accessories	30	AMPOUTb	Bch Internal OP-AMP Output
9	ealaBASS LPF1	ealaBASS Filter Capacitor 1	31	AMP-INb	Bch Internal OP-AMP -Input
10	ealaBASS SENSE	ealaBASS Sensitivity Adjustment Resistance	32	AMP+INb	Bch Internal OP-AMP +Input
11	ealaBASS INT	ealaBASS Smoothing Filter Capacitor	33	OUTb	Bch Output
12	OUTa	Ach Output	34	CBB	Pop Noise Capacitor for ealaBASS
13	AMP+INa	Ach Internal OP-AMP +Input	35	ealaBASS LPF2	ealaBASS Filter Capacitor 2
14	AMP-INa	Ach Internal OP-AMP -Input	36	ealaBASS LPF3	ealaBASS Filter Capacitor 3
15	AMPOUTa	Ach Internal OP-AMP Output	37	RETURNb	Bch Input from the other accessories
16	AGC INT	AGC Smoothing Filter Capacitor	38	SENDb	Bch Input for the other accessories
17	CVa	Pop Noise Reduction Capacitor for Volume	39	BBELb	Bch BBE Filter2 (Process)
18	CVb	Pop Noise Reduction Capacitor for Balance	40	BBEHb	Bch BBE Filter1 (Lo Contour)
19	CSR	Pop Noise Reduction Capacitor for Surround	41	TONE-Lb	Bch Tone Bass Filter Capacitor
20	SDA	SDA Data Input (I ² C BUS)	42	TONE-Hb	Bch Tone Treble Filter Capacitor
21	SCL	SCL Data Input (I ² C BUS)	43	SRS FIL	SRS Filter Capacitor
22	GND	GND	44	INb	Bch Input

■ABSOLUTE MAXIMUM RATING (Ta=25°C)

PARAMETER	SYMBOL	RATING	UNIT
Supply Voltage	V ⁺	15	V
Power Dissipation	P _D	800 NOTE: EIA/JEDEC STANDARD Test board (76.2x114.3x1.6mm, 2layer, FR-4) mounting	mW
Operating Temperature Range	Topr	-20 to +75	°C
Storage Temperature Range	Tstg	-40 to +125	°C

■ELECTRICAL CHARACTERISTICS

(Ta=25°C, V⁺=9V, R_g=600Ω, R_l=47kΩ, Vin=100mVrms/1kHz unless otherwise specified)

PARAMETER	SYMBOL	TEST CONDITION	MIN	TYP	MAX	UNIT
Operating Voltage	V ⁺		7.5	9.0	13.0	V
Supply Current	I _{CC}	No Signal	-	15	25	mA
Reference Voltage	V _{REF}	No Signal	4.0	4.5	5.0	V
Maximum Input Voltage	V _{IM}	VOL=-20dB, THD=10%	2.8	3.0	-	Vrms
Maximum Output Voltage	V _{OM}	OUTPUT VOL=0dB, THD=1%	-	2.5	-	Vrms
Channel Balance	G _{CB}	VOL=0dB	-1.0	0.0	1.0	dB
Balance Boost A	BA _{BST}	CHS="0", BAL="11111"	-2.0	0.0	2.0	dB
Balance Cut A	BA _{CUT}	CHS="1", BAL="11111" Vin = 1Vrms	-	-	-70	dB
Balance Boost B	BB _{BST}	CHS="1", BAL="11111"	-2.0	0.0	2.0	dB
Balance Cut B	BB _{CUT}	CHS="0", BAL="11111" Vin = 1Vrms	-	-	-70	dB
Total Harmonic Distortion	THD	Vo=0.5Vrms BW=400Hz ~ 30kHz	-	-	0.3	%
Maximum Gain	G _{VMAX}	VOL= 0dB	-2.0	0.0	2.0	dB
Minimum Gain	G _{VMIN}	VOL= MUTE , Vin = 2Vrms	-	-100	-90	dB
Channel Separation	CS	Vin = 1Vrms, A-weighted	-	-80	-70	dB
Output Noise 1	V _{NO1}	VOL= 0dB A-weighted	-	-90 (31.6)	-85 (56.2)	dBV (μVrms)
Output Noise 2	V _{NO2}	VOL = MUTE A-weighted	-	-106 (5.0)	-96 (15.8)	dBV (μVrms)
AUX Output Voltage	V _{AUX}	Logic Output: High	4.5	-	5.0	V
		Logic Output: Low	0		0.3	

BW: Band Width

◆TONE

PARAMETER	SYMBOL	TEST CONDITION	MIN	TYP	MAX	UNIT
Treble Boost	HF _{BST}	BCT="1",TREB="1111", f=10kHz	12.5	15.0	17.5	dB
Treble Flat	HF _{FLT}	TREB="0000",f=10kHz	-2.0	0.0	2.0	dB
Treble Cut	HF _{CUT}	BCT="0",TREB="1111", f=10kHz	-17.5	-15.0	-12.5	dB
Bass Boost	LF _{BST}	BCB="1",BASS="1111", f=100Hz	12.5	15.0	17.5	dB
Bass Flat	LF _{FLT}	BASS="0000",f=100Hz	-2.0	0.0	2.0	dB
Bass Cut	LF _{CUT}	BCB="0",BASS="1111", f=100Hz	-17.5	-15.0	-12.5	dB

◆AGC

PARAMETER	SYMBOL	TEST CONDITION	MIN	TYP	MAX	UNIT
AGC Boost	AGC _{BST}	Vin=50mVrms, f=1kHz	1.5	3.5	5.5	dB
AGC Flat 1	AGC _{FLT1}	Vin=100mVrms, f=1kHz	-2.5	0.0	2.5	dB
AGC Flat 2	AGC _{FLT2}	Vin=200mVrms, f=1kHz	-2.5	0.0	2.5	dB
AGC Flat 3	AGC _{FLT3}	Vin=300mVrms, f=1kHz	-2.5	0.0	2.5	dB
AGC Flat 4	AGC _{FLT4}	Vin=400mVrms, f=1kHz	-2.5	0.0	2.5	dB
AGC Cut	AGC _{CUT}	Vin=2Vrms, f=1kHz	-14	-10	-6.0	dB

◆BBE (BBE-ON)

PARAMETER	SYMBOL	TEST CONDITION	MIN	TYP	MAX	UNIT
BBE Bass Control Range	BBE _{LOW}	BBE-Low="1111", f=50Hz	-	15.0	-	dB
BBE Treble Control Range	BBE _{HIGH}	BBE-High="1111", f=10KHz	-	15.0	-	dB

◆SIMULATED STEREO (Simulated Stereo ON, f=1kHz)

PARAMETER	SYMBOL	TEST CONDITION	MIN	TYP	MAX	UNIT
Simulated Stereo A	SR _{SIMA}	Ain+Bin → Aout	1.0	3.0	5.0	dB
Simulated Stereo B	SR _{SIMB}	Ain+Bin → Bout	1.0	3.0	5.0	dB

◆SURROUND EFFECT(SRS 3D: f=125Hz eala : f=100Hz)

PARAMETER	SYMBOL	TEST CONDITION	MIN	TYP	MAX	UNIT
SRS Gain HIGH 1	SRS _{GH1}	Ain → Aout, Mode=High	9.5	11.5	13.5	dB
SRS Gain HIGH 2	SRS _{GH2}	Ain → Bout, Mode=High	6.5	8.5	10.5	dB
SRS Gain LOW	SRS _{GL}	Ain → Aout, Mode=Low	4.0	6.0	8.0	dB
eala Gain HIGH 1	SR _{GH1}	Ain → Aout, Mode=High	8.0	10.0	12.0	dB
eala Gain HIGH 2	SR _{GH2}	Ain → Bout, Mode=High	4.5	6.5	8.5	dB
eala Gain LOW	SR _{GL}	Ain → Aout, Mode=Low	2.0	4.0	6.0	dB

◆BassBoost(f=100Hz)

PARAMETER	SYMBOL	TEST CONDITION	MIN	TYP	MAX	UNIT
BassBoost Gain 1	BB _{GV1}	A+Bin → Aout, BB1="1",BB0="1"	-	9.0	-	dB
BassBoost Gain 2	BB _{GV2}	A+Bin → Aout, BB1="1",BB0="0"	-	6.0	-	dB
BassBoost Gain 3	BB _{GV3}	A+Bin → Aout, BB1="0",BB0="1"	-	3.0	-	dB

■TIMING ON THE I²C BUS (SDA,SCL)

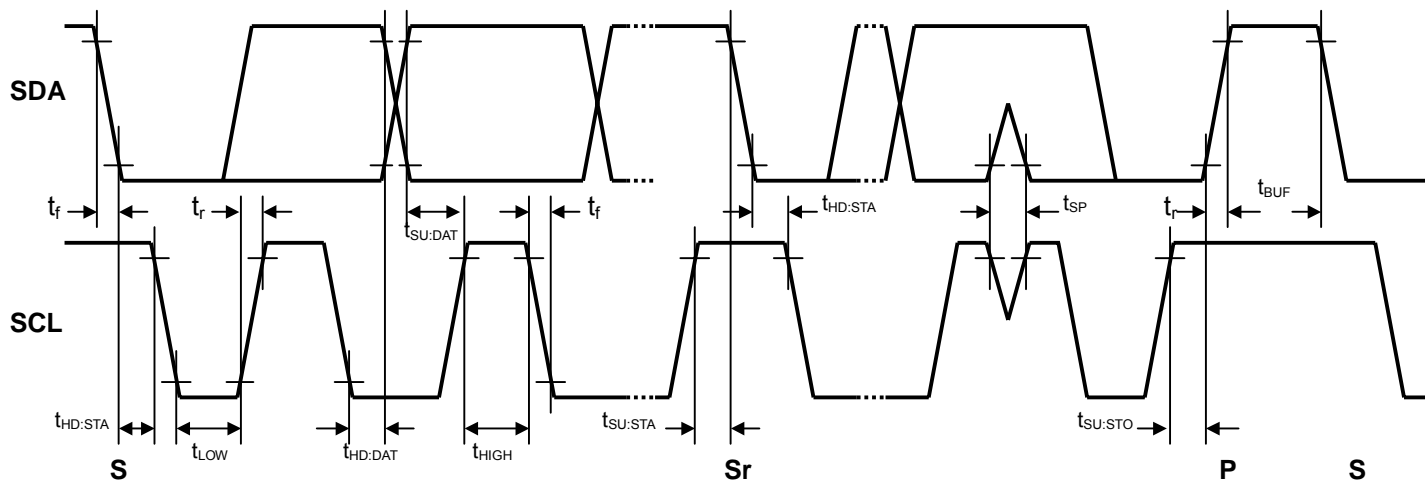

■CHARACTERISTICS OF I/O STAGES FOR I²C BUS (SDA,SCL)

I²C BUS Load Conditions

STANDARD MODE : Pull up resistance 4kΩ (Connected to +5V), Load capacitance 200pF (Connected to GND)

FAST MODE : Pull up resistance 4kΩ (Connected to +5V), Load capacitance 50pF (Connected to GND)

PARAMETER	SYMBOL	Standard mode			Fast mode			UNIT
		MIN.	TYP.	MAX.	MIN.	TYP.	MAX.	
Low Level Input Voltage	V _{IL}	0.0	-	1.5	0.0	-	1.5	V
High Level Input Voltage	V _{IH}	2.7	-	5.0	2.7	-	5.0	V
Low level output voltage (3mA at SDA pin)	V _{OL}	0	-	0.4	0	-	0.4	V
Input current each I/O pin with an input voltage between 0.1V _{DD} and 0.9V _{DDmax}	I _i	-10	-	10	-10	-	10	μA

■CHARACTERISTICS OF BUS LINES (SDA,SCL) FOR I²C-BUS DEVICES

PARAMETER	SYMBOL	Standard mode			Fast mode			UNIT
		MIN.	TYP.	MAX.	MIN.	TYP.	MAX.	
SCL clock frequency	f _{SCL}	-	-	100	-	-	400	kHz
Hold time (repeated) START condition.	t _{HD:STA}	4.0	-	-	0.6	-	-	μs
Low period of the SCL clock	t _{LOW}	4.7	-	-	1.3	-	-	μs
High period of the SCL clock	t _{HIGH}	4.0	-	-	0.6	-	-	μs
Set-up time for a repeated START condition	t _{SU:STA}	4.7	-	-	0.6	-	-	μs
Data hold time ^(NOTE)	t _{HD:DAT}	0	-	-	0	-	-	μs
Data set-up time	t _{SU:DAT}	250	-	-	100	-	-	ns
Rise time of both SDA and SCL signals	t _r	-	-	1000	-	-	300	ns
Fall time of both SDA and SCL signals	t _f	-	-	300	-	-	300	ns
Set-up time for STOP condition	t _{SU:STO}	4.0	-	-	0.6	-	-	μs
Bus free time between a STOP and START condition	t _{BUF}	4.7	-	-	1.3	-	-	μs
Capacitive load for each bus line	C _b	-	-	400	-	-	400	pF
Noise margin at the Low level	V _{nL}	0.5	-	-	0.5	-	-	V
Noise margin at the High level	V _{nH}	1	-	-	1	-	-	V

C_b ; total capacitance of one bus line in pF.

NOTE). Data hold time : t_{HD:DAT}

Please hold the Data Hold Time (t_{HD:DAT}) to 300ns or more to avoid status of unstable at SCL falling edge.

The SDA block in the NJW1177 does not hold data. Add external data-delay-circuit of the SDA terminal, in case of not providing a hold time of at least 300nsec for the SDA in the master device.

The time-consists of the data-delay-circuit of the SDA terminal are as follows.

- (a) Low level → High level : $T_{LH} \approx R_P * C_D$
- (b) High level → Low level : $T_{HL} \approx R_D * C_D$

In addition, Schottky barrier diode (SBD) influences a Low level at the Acknowledge. Therefore choose the low forward voltage (V_f) as much as possible.

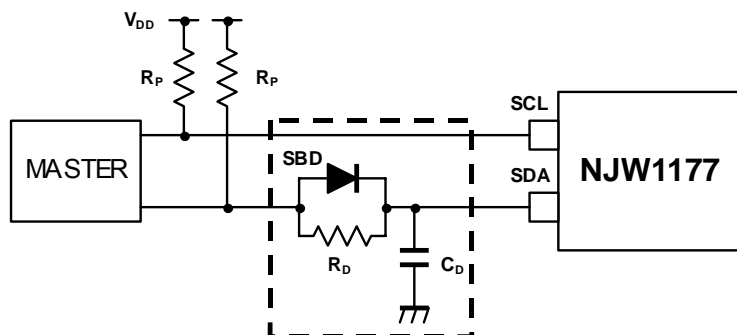

■TERMINAL DESCRIPTION

No.	SYMBOL	FUNCTION	EQUIVALENT CIRCUIT	VOLTAGE
1 44	INa INb	Ach Input Bch Input		V+/2
2	SURROUND FIL	Surround Filter Capacitor		V+/2
3 42	TONE-Ha TONE-Hb	Ach TONE Treble Filter Capacitor Bch TONE Treble Filter Capacitor		V+/2
4 41	TONE-La TONE-Lb	Ach TONE Bass Filter Capacitor Bch TONE Bass Filter Capacitor		V+/2
5 6 40 39	BBEHa BBELa BBEHb BBELb	Ach BBE Filter 1 (Process) Ach BBE Filter 2 (Lo Contour) Bch BBE Filter 1 (Process) Bch BBE Filter 2 (Lo Contour)		V+/2

■TERMINAL DESCRIPTION

No.	SYMBOL	FUNCTION	EQUIVALENT CIRCUIT	VOLTAGE
7 38 12 33 15 30	SENDa SENDb OUTa OUTb AMPOUTa AMPOUTb	Ach output for the other accessories Bch output for the other accessories Ach Output Bch Output Ach Internal OP-AMP Output Bch Internal OP-AMP Output		V+/2
8 37	RETURNa RETURNb	Ach Input from the other accessories Bch Input from the other accessories		V+/2
9	ealaBASS LPF1	ealaBASS Filter Capacitor 1		V+/2
10	ealaBASS SENSE	ealaBASS Sensitivity Adjustment Resistance		0V
11	ealaBASS INT	ealaBASS Smoothing Filter Capacitor		0V

■TERMINAL DESCRIPTION

No.	SYMBOL	FUNCTION	EQUIVALENT CIRCUIT	VOLTAGE
13 32 14 31	AMP+INa AMP+INb AMP-INa AMP-INb	Ach Internal OP-AMP + Input Bch Internal OP-AMP + Input Ach Internal OP-AMP - Input Bch Internal OP-AMP - Input		-
16	AGC INT	AGC Smoothing Filter		1.4V
17 18	CVa CVb	Pop Noise Reduction Capacitor for Volume Pop Noise Reduction Capacitor for Balance		VREF-0.7V (Volume=0dB) (Balance=Center)
19 34	CSR CBB	Pop Noise Reduction Capacitor for Surround Pop Noise Reduction Capacitor for ealaBASS		0.9V (Surround = OFF) (Bass Boost = OFF)
20 21	SDA SCL	SDA Data Input (I ² C BUS) SCL Data Input (I ² C BUS)		-
22 23	GND V+	GND Power Supply Input	-	-

■TERMINAL DESCRIPTION

No.	SYMBOL	FUNCTION	EQUIVALENT CIRCUIT	VOLTAGE
24 25	AUX1 AUX0	Auxiliary Output 1 Auxiliary Output 0		0V / 5V
26	VREF	Reference Voltage Stabilizing Capacitor		V+/2
27 28	CTL CTH	Pop Noise Reduction Capacitor for TONE Bass Pop Noise Reduction Capacitor for TONE Treble		VREF-0.7V (TONE=Flat)
29	CBH	Pop Noise Reduction Capacitor for BBE		VREF-0.7V (BBE=OFF)
35	ealaBASS LPF2	ealaBASS Filter Capacitor 2		V+/2

■TERMINAL DESCRIPTION

No.	SYMBOL	FUNCTION	EQUIVALENT CIRCUIT	VOLTAGE
36	ealaBASS LPF3	ealaBASS Filter Capacitor 3		V+/2
43	SRS FIL	SRS Filter Capacitor		V+/2

APPLICATION CIRCUIT 1

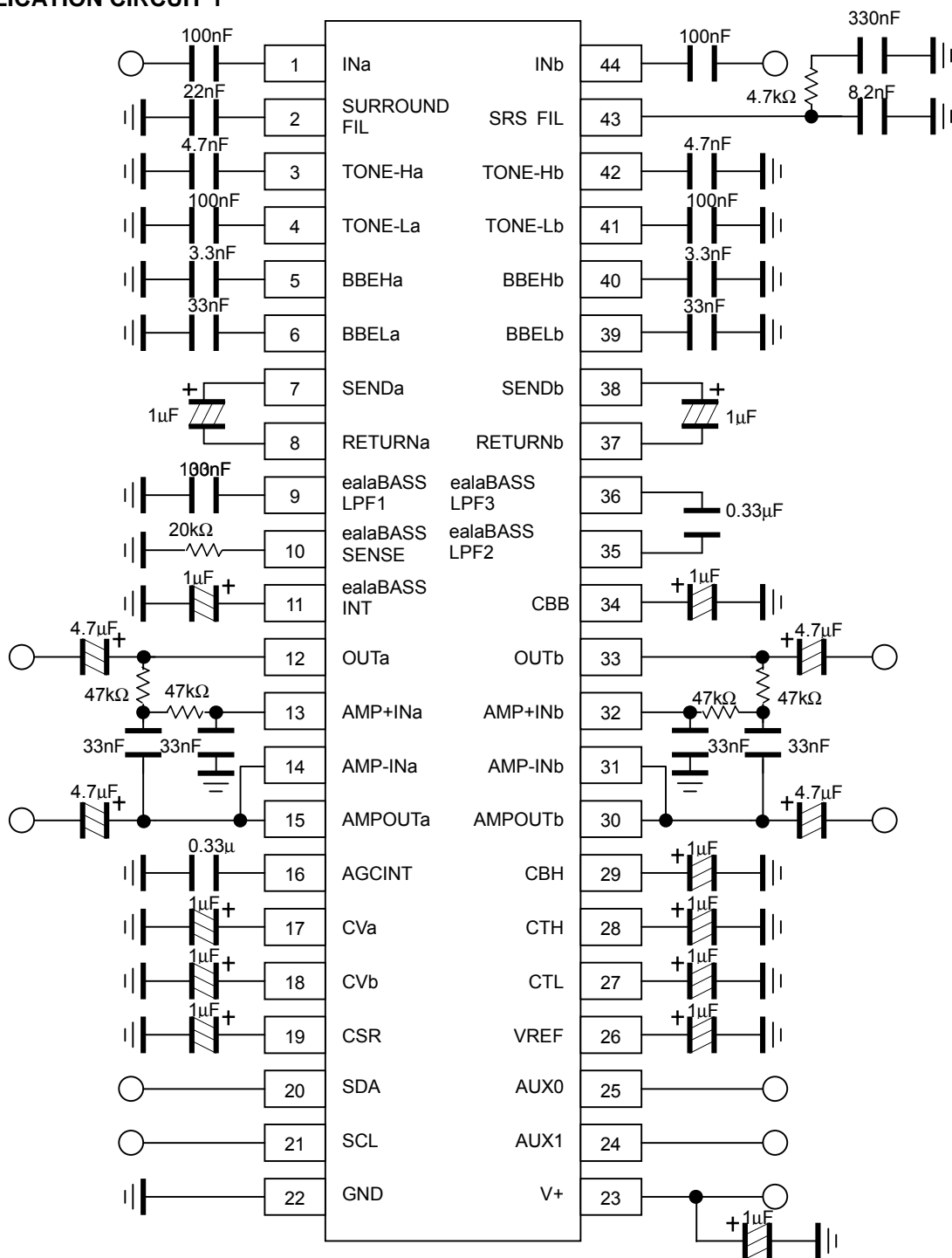

(*) Separate the I²C bus line and Signal line from the following terminals for avoiding digital noise problem and cross talk.

Pin No.	Symbol	Pin No.	Symbol	Pin No.	Symbol	Pin No.	Symbol
2	SURROUND FIL	6	BBELa	35	ealaBASS LPF2	41	TONE-Lb
3	TONE-Ha	9	ealaBASS LPF1	36	ealaBASS LPF3	42	TONE-Hb
4	TONE-La	10	ealaBASS SENSE	39	BBELb	-	-
5	BBEHa	11	ealaBASS INT	40	BBEHb	-	-

■APPLICATION CIRCUIT 2

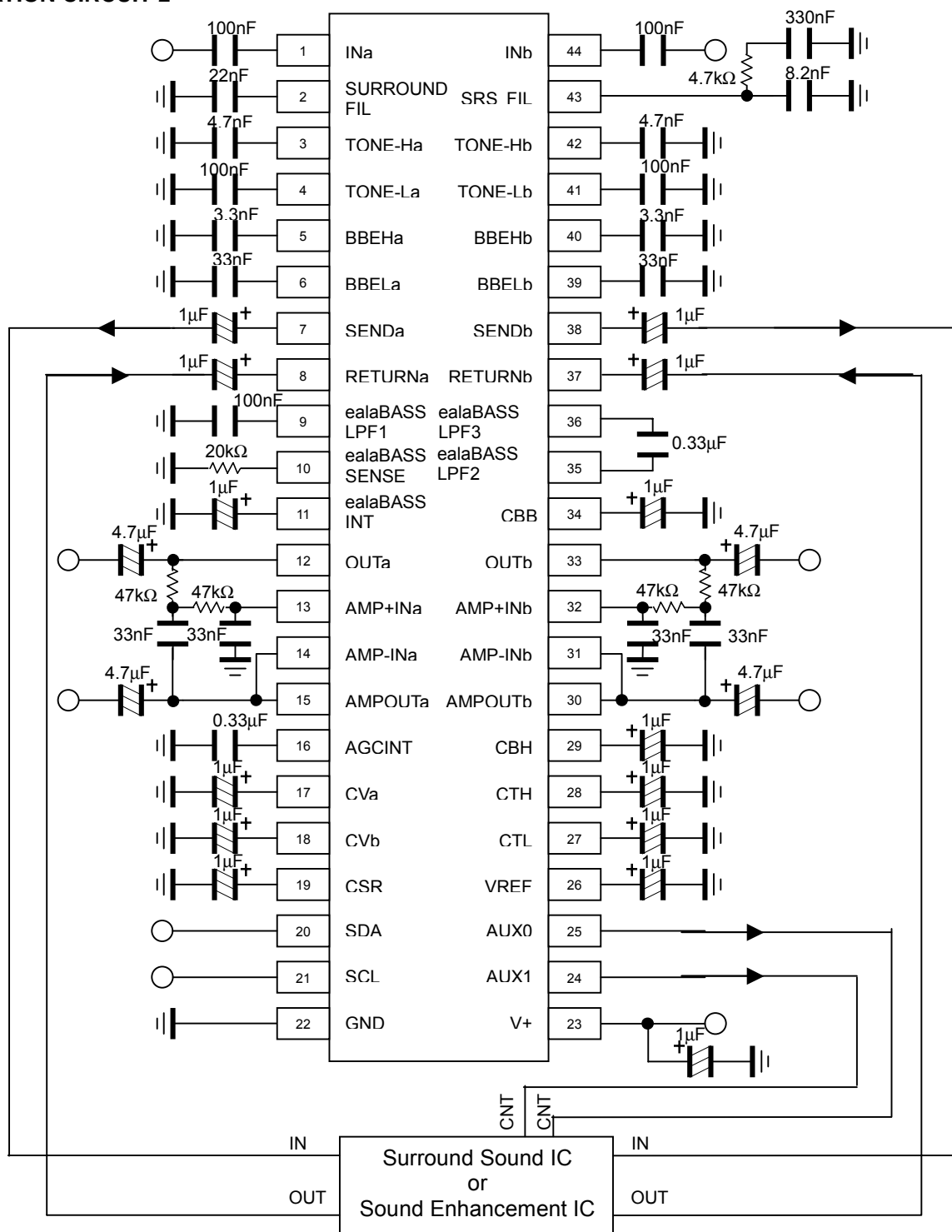

Ex.) BBE Mach3 : NJM2155
 SRS TruBass : NJM2192A,
 SRS WOW : NJM2700, NJM2195, ... , etc

(*) Separate the I²C bus line and Signal line from the following terminals for avoiding digital noise problem and cross talk.

Pin No.	Symbol	Pin No.	Symbol	Pin No.	Symbol	Pin No.	Symbol
2	SURROUND FIL	6	BBELa	35	ealaBASS LPF2	41	TONE-Lb
3	TONE-Ha	9	ealaBASS LPF1	36	ealaBASS LPF3	42	TONE-Hb
4	TONE-La	10	ealaBASS SENSE	39	BBELb	-	-
5	BBEHa	11	ealaBASS INT	40	BBEHb	-	-

■ DEFINITION OF I²C REGISTER

◆ I²C BUS FORMAT

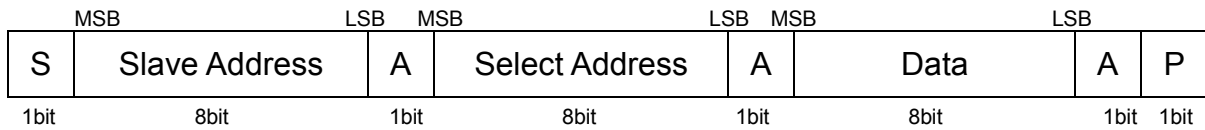

S: Starting Term
 A: Acknowledge Bit
 P: Ending Term

◆ SLAVE ADDRESS



$\overline{R/W}=0$: Receive Only
 $\overline{R/W}=1$: No Output Data

◆ CONTROL REGISTER TABLE

The select address sets each function (Volume, Balance, AGC, Surround, Tone Control, BBE, ealaBASS, AUX).

The auto increment function cycles the select address as follows.

00H→01H→02H→03H→04H→05H→00H

Select Address	BIT							
	D7	D6	D5	D4	D3	D2	D1	D0
00H	VOL							
01H	CHS	BAL				AGC	SUR	
02H	BCB	BASS			Don't Care	Don't Care	Don't Care	
03H	BCT	TREB			Don't Care	Don't Care	Don't Care	
04H	BBE-Low (Lo Contour)				BBE-High (Process)			
05H	ealaBASS	SUR1	SUR0	AGC1	AGC0	AUX1	AUX0	

◆ CONTROL REGISTER DEFAULT VALUE

Control register default value is all "0".

Select Address	BIT							
	D7	D6	D5	D4	D3	D2	D1	D0
00H	0	0	0	0	0	0	0	0
01H	0	0	0	0	0	0	0	0
02H	0	0	0	0	0	0	0	0
03H	0	0	0	0	0	0	0	0
04H	0	0	0	0	0	0	0	0
05H	0	0	0	0	0	0	0	0

■INSTRUCTION CODE

a)MASTER VOLUME SETTING

Select Address	BIT							
	D7	D6	D5	D4	D3	D2	D1	D0
00H	VOL							

◆VOL Attenuation Level setting

The volume control for both Ach and Bch(0.33dB/step).

The volume is consisted of volume1 and volume2 and the level is divided into half to each volume1 and volume2.

b)BALANCE, AGC, SURROUND SETTING

Select Address	BIT							
	D7	D6	D5	D4	D3	D2	D1	D0
01H	CHS	BAL					AGC	SUR

- CHS : Channel select for balance control

“0” = Ach, (Bch is attenuated)

“1” = Bch, (Ach is attenuated)

- BAL : Balance control for both Ach and Bch (1dB/step)

The balance is consisted of volume1 and volume2.

- AGC : AGC ON/OFF switch

“0” = AGC OFF

“1” = AGC ON (Default : 100mVrms)

- SUR : Surround ON/OFF switch

“0” = Surround OFF

“1” = Surround ON(Default : Surround Effect 1)

c)TONE CONTROL BASS SETTING

Select Address	BIT								
	D7	D6	D5	D4	D3	D2	D1	D0	
02H	BCB	BASS					Don't Care	Don't Care	Don't Care

- BCB : Boost cut select for BASS control

“0” = Cut

“1” = Boost

- BASS: BASS Control

Cut Level : 0dB to -15dB(1dB/step)

Boost Level : 0dB to 15dB(1dB/step)

d)TONE CONTROL TREBLE SETTING

Select Address	BIT								
	D7	D6	D5	D4	D3	D2	D1	D0	
03H	BCT	TREB					Don't Care	Don't Care	Don't Care

- BCT : Boost cut select for Treble control

“0” = Cut

“1” = Boost

- TREB: Treble level setting

Cut Level : 0dB to -15dB(1dB/step)

Boost Level : 0dB to 15dB(1dB/step)

e)BBE SETTING

Select Address	BIT							
	D7	D6	D5	D4	D3	D2	D1	D0
04H	BBE-Low(Lo Contour)				BBE-High(Process)			

- BBE-Low: BBE Bass Boost(Lo Contour) setting
Boost Level : 0dB to 15dB(1dB/step)
- BBE-High: BBE Treble Boost (Process) setting
Boost Level : 0dB to 15dB(1dB/step)

When all bits are "0"(00H), BBE becomes off.

f)OUTPUT, AGC LEVEL, SURROUND LEVEL, AND AUXILIARY SETTING

Select Address	BIT							
	D7	D6	D5	D4	D3	D2	D1	D0
05H	BB1	BB0	SUR1	SUR0	AGC1	AGC0	AUX1	AUX0

- OUT: Output ON/OFF switch
"0" = OFF
"1" = ON

- AGC Level setting by AGC1, AGC0

AGC level	AGC1	AGC0
100mVrms	0	0
200mVrms	0	1
300mVrms	1	0
400mVrms	1	1

- Surround effect and simulated stereo setting by SUR(01H:D0), SUR1(05H:D5),SUR0(05H:D4)

Surround function	SUR1	SUR0	SUR	Remarks
Surround OFF	0	0	0	Surround OFF
eala effect 1	0	1	0	eala effect small
eala effect 2	0	1	1	eala effect large
SRS effect 1	1	0	0	SRS effect small
SRS effect 2	1	0	1	SRS effect large
Simulated stereo	0	0	1	For monaural signal input only

- ealaBASS setting

Function	05H:D7	05H:D6	Remarks
BassBoostOFF	0	0	BassBoostOFF
BassBoost1	0	1	BassBoost effect small
BassBoost2	1	0	BassBoost effect middle
BassBoost3	1	1	BassBoost effect large

- AUX1/AUX0: Output setting for auxiliary port
"0" = Logic output "Low"
"1" = Logic output "High"

■MASTER VOLUME (Select Address : 00H)

		VOL							
Gain (dB)	HEX	D7	D6	D5	D4	D3	D2	D1	D0
0	FF	1	1	1	1	1	1	1	1
-1	FC	1	1	1	1	1	1	0	0
-2	F9	1	1	1	1	1	0	0	1
-3	F6	1	1	1	1	0	1	1	0
-4	F3	1	1	1	1	0	0	1	1
-5	F0	1	1	1	1	0	0	0	0
-6	ED	1	1	1	0	1	1	0	1
-7	EA	1	1	1	0	1	0	1	0
-8	E7	1	1	1	0	0	1	1	1
-9	E4	1	1	1	0	0	1	0	0
-10	E1	1	1	1	0	0	0	0	1
-11	DE	1	1	0	1	1	1	1	0
-12	DB	1	1	0	1	1	0	1	1
-13	D8	1	1	0	1	1	0	0	0
-14	D5	1	1	0	1	0	1	0	1
-15	D2	1	1	0	1	0	0	1	0
-16	CF	1	1	0	0	1	1	1	1
-17	CC	1	1	0	0	1	1	0	0
-18	C9	1	1	0	0	1	0	0	1
-19	C6	1	1	0	0	0	1	1	0
-20	C3	1	1	0	0	0	0	1	1
-21	C0	1	1	0	0	0	0	0	0
-22	BD	1	0	1	1	1	1	0	1
-23	BA	1	0	1	1	1	0	1	0
-24	B7	1	0	1	1	0	1	1	1
-25	B4	1	0	1	1	0	1	0	0
-26	B1	1	0	1	1	0	0	0	1
-27	AE	1	0	1	0	1	1	1	0
-28	AB	1	0	1	0	1	0	1	1
-29	A8	1	0	1	0	1	0	0	0
-30	A5	1	0	1	0	0	1	0	1
-31	A2	1	0	1	0	0	0	1	0
-32	9F	1	0	0	1	1	1	1	1
-33	9C	1	0	0	1	1	1	0	0
-34	99	1	0	0	1	1	0	0	1
-35	96	1	0	0	1	0	1	1	0
-36	93	1	0	0	1	0	0	1	1
-37	90	1	0	0	1	0	0	0	0
-38	8D	1	0	0	0	1	1	0	1
-39	8A	1	0	0	0	1	0	1	0
-40	87	1	0	0	0	0	1	1	1
-41	84	1	0	0	0	0	1	0	0
-42	81	1	0	0	0	0	0	0	1

■MASTER VOLUME (Select Address : 00H)

		VOL							
Gain (dB)	HEX	D7	D6	D5	D4	D3	D2	D1	D0
-43	7E	0	1	1	1	1	1	1	0
-44	7B	0	1	1	1	1	0	1	1
-45	78	0	1	1	1	1	0	0	0
-46	75	0	1	1	1	0	1	0	1
-47	72	0	1	1	1	0	0	1	0
-48	6F	0	1	1	0	1	1	1	1
-49	6C	0	1	1	0	1	1	0	0
-50	69	0	1	1	0	1	0	0	1
-51	66	0	1	1	0	0	1	1	0
-52	63	0	1	1	0	0	0	1	1
-53	60	0	1	1	0	0	0	0	0
-54	5D	0	1	0	1	1	1	0	1
-55	5A	0	1	0	1	1	0	1	0
-56	57	0	1	0	1	0	1	1	1
-57	54	0	1	0	1	0	1	0	0
-58	51	0	1	0	1	0	0	0	1
-59	4E	0	1	0	0	1	1	1	0
-60	4B	0	1	0	0	1	0	1	1
-61	48	0	1	0	0	1	0	0	0
-62	45	0	1	0	0	0	1	0	1
-63	42	0	1	0	0	0	0	1	0
-64	3F	0	0	1	1	1	1	1	1
-65	3C	0	0	1	1	1	1	0	0
-66	39	0	0	1	1	1	0	0	1
-67	36	0	0	1	1	0	1	1	0
-68	33	0	0	1	1	0	0	1	1
-69	30	0	0	1	1	0	0	0	0
-70	2D	0	0	1	0	1	1	0	1
-71	2A	0	0	1	0	1	0	1	0
-72	27	0	0	1	0	0	1	1	1
-73	24	0	0	1	0	0	1	0	0
-74	21	0	0	1	0	0	0	0	1
-75	1E	0	0	0	1	1	1	1	0
-76	1B	0	0	0	1	1	0	1	1
-77	18	0	0	0	1	1	0	0	0
-78	15	0	0	0	1	0	1	0	1
-79	12	0	0	0	1	0	0	1	0
-80	0F	0	0	0	0	1	1	1	1
-81	0C	0	0	0	0	1	1	0	0
-82	09	0	0	0	0	1	0	0	1
-83	06	0	0	0	0	0	1	1	0
-84	03	0	0	0	0	0	0	1	1
Mute	00	0	0	0	0	0	0	0	0

■BALANCE (Select Address : 01H)

Channel Select (CHS)	D7
Ach(Bch is attenuate)	0
Bch(Ach is attenuate)	1

Gain(dB)	BAL				
	D6	D5	D4	D3	D2
0	0	0	0	0	0
-1	0	0	0	0	1
-2	0	0	0	1	0
-3	0	0	0	1	1
-4	0	0	1	0	0
-5	0	0	1	0	1
-6	0	0	1	1	0
-7	0	0	1	1	1
-8	0	1	0	0	0
-9	0	1	0	0	1
-10	0	1	0	1	0
-11	0	1	0	1	1
-12	0	1	1	0	0
-13	0	1	1	0	1
-14	0	1	1	1	0
-15	0	1	1	1	1
-16	1	0	0	0	0
-17	1	0	0	0	1
-18	1	0	0	1	0
-19	1	0	0	1	1
-20	1	0	1	0	0
-21	1	0	1	0	1
-22	1	0	1	1	0
-23	1	0	1	1	1
-24	1	1	0	0	0
-25	1	1	0	0	1
-26	1	1	0	1	0
-27	1	1	0	1	1
-28	1	1	1	0	0
-29	1	1	1	0	1
-30	1	1	1	1	0
Mute	1	1	1	1	1

■TONE CONTROL BASS (Select Address : 02H)

Bass Cut or Boost	BCB
	D7
Cut	0
Boost	1

		BASS			
		D6	D5	D4	D3
Cut Gain(dB)	Boost Gain(dB)				
-15	15	1	1	1	1
-14	14	1	1	1	0
-13	13	1	1	0	1
-12	12	1	1	0	0
-11	11	1	0	1	1
-10	10	1	0	1	0
-9	9	1	0	0	1
-8	8	1	0	0	0
-7	7	0	1	1	1
-6	6	0	1	1	0
-5	5	0	1	0	1
-4	4	0	1	0	0
-3	3	0	0	1	1
-2	2	0	0	1	0
-1	1	0	0	0	1
0	0	0	0	0	0

■TONE CONTROL TREBLE (Select Address : 03H)

Treble Cut or Boost	BCT
	D7
Cut	0
Boost	1

		TREB			
		D6	D5	D4	D3
Cut Gain(dB)	Boost Gain(dB)				
-15	15	1	1	1	1
-14	14	1	1	1	0
-13	13	1	1	0	1
-12	12	1	1	0	0
-11	11	1	0	1	1
-10	10	1	0	1	0
-9	9	1	0	0	1
-8	8	1	0	0	0
-7	7	0	1	1	1
-6	6	0	1	1	0
-5	5	0	1	0	1
-4	4	0	1	0	0
-3	3	0	0	1	1
-2	2	0	0	1	0
-1	1	0	0	0	1
0	0	0	0	0	0

■BBE Low(Lo Contour) / High(Process) GAIN CODE (Select Address : 04H)

		Lo Contour				Process			
Cut Gain(dB)	Boost Gain(dB)	D7	D6	D5	D4	D3	D2	D1	D0
-15	15	1	1	1	1	1	1	1	1
-14	14	1	1	1	0	1	1	1	0
-13	13	1	1	0	1	1	1	0	1
-12	12	1	1	0	0	1	1	0	0
-11	11	1	0	1	1	1	0	1	1
-10	10	1	0	1	0	1	0	1	0
-9	9	1	0	0	1	1	0	0	1
-8	8	1	0	0	0	1	0	0	0
-7	7	0	1	1	1	0	1	1	1
-6	6	0	1	1	0	0	1	1	0
-5	5	0	1	0	1	0	1	0	1
-4	4	0	1	0	0	0	1	0	0
-3	3	0	0	1	1	0	0	1	1
-2	2	0	0	1	0	0	0	1	0
-1	1	0	0	0	1	0	0	0	1
0	0	0	0	0	0	0	0	0	0

TYPICAL CHARACTERISTICS

Supply Current vs. Supply Voltage

Ta=25°C

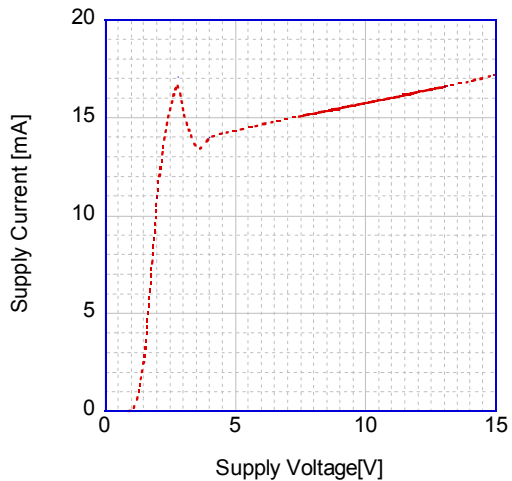

Supply Current vs. Temperature

V⁺=9V

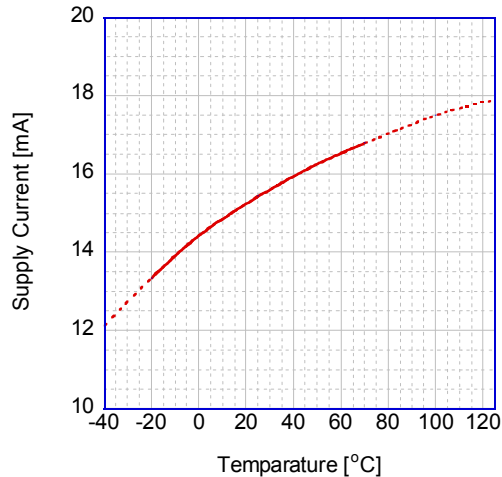

Reference Voltage vs. Supply Voltage

Ta=25°C

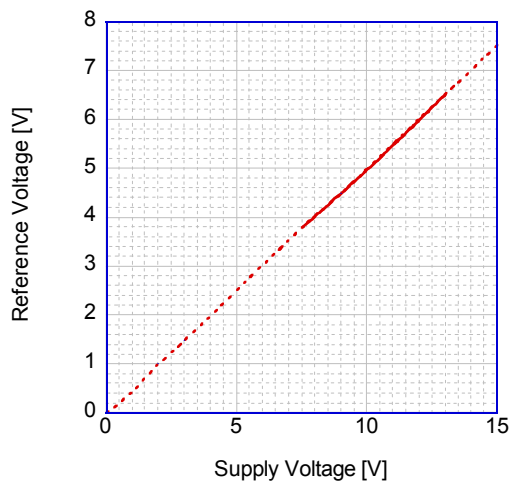

Reference Voltage vs. Temperature

V⁺=9V

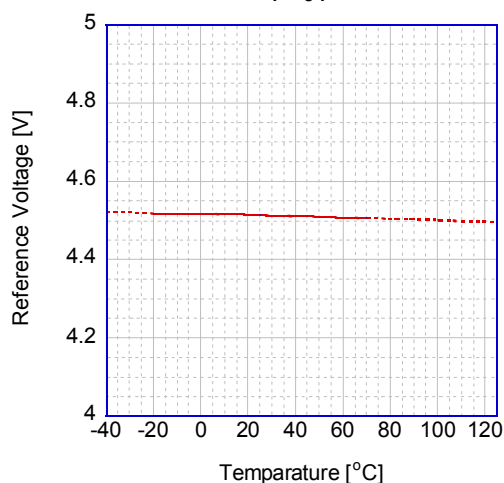

Gain vs. VOLUME Control

V⁺=9V, Vin=1Vrms, f=1kHz,

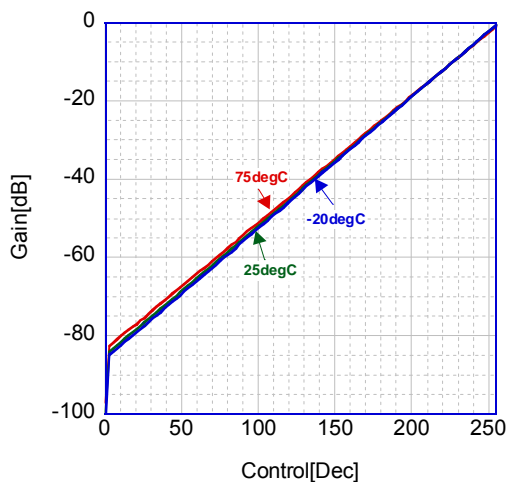

Gain vs. BALANCE Control

V⁺=9V, Vin=1Vrms, f=1kHz

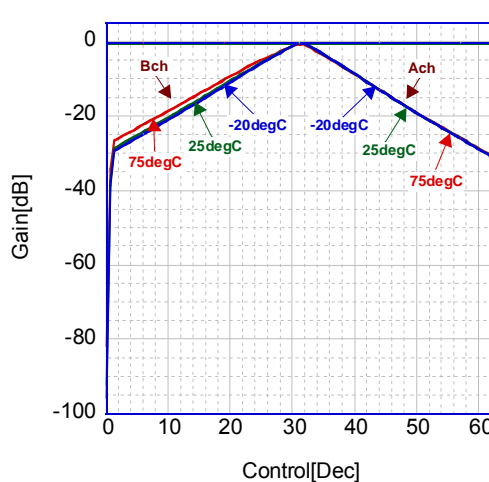

TYPICAL CHARACTERISTICS

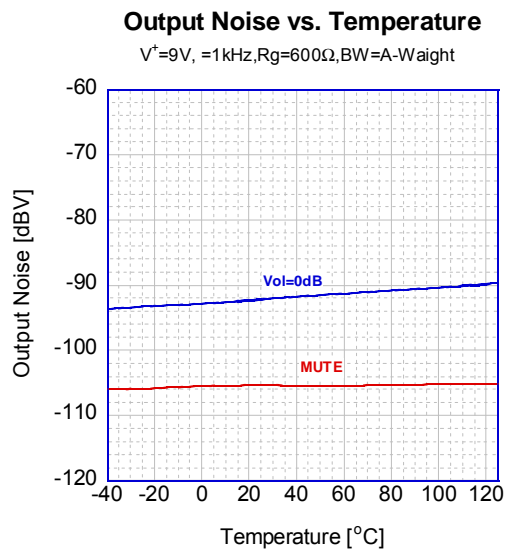
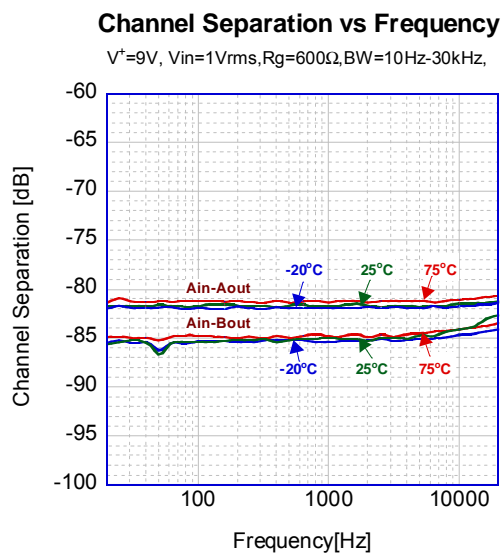
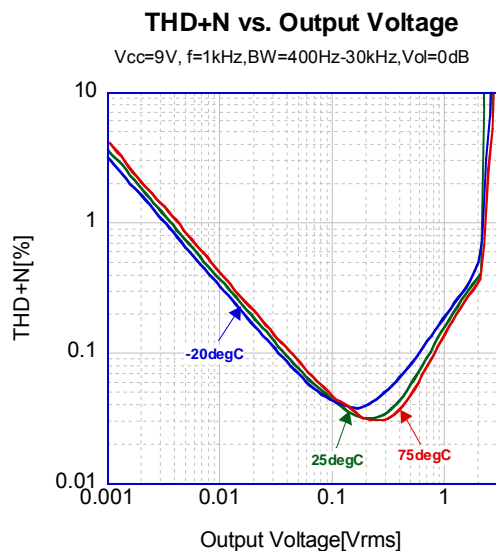
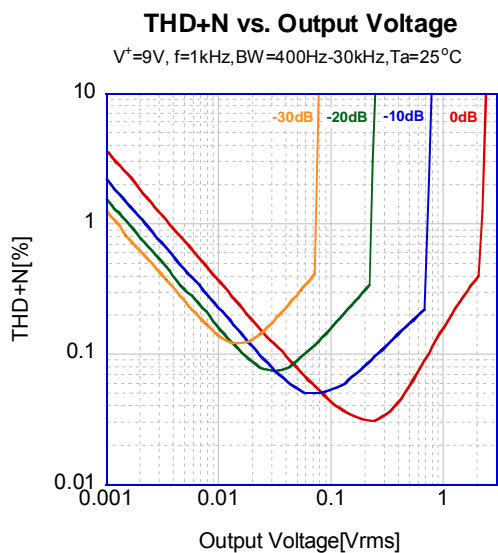
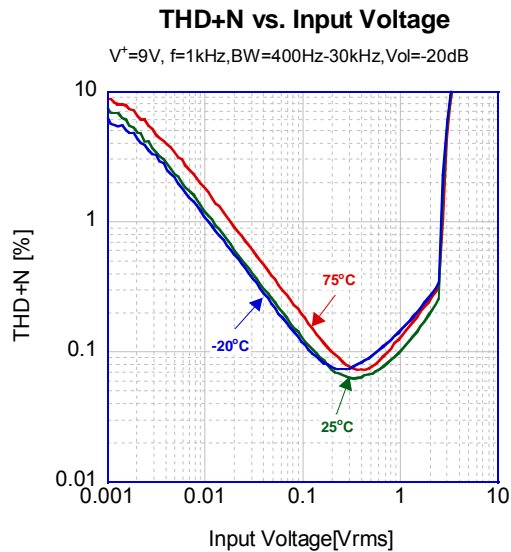
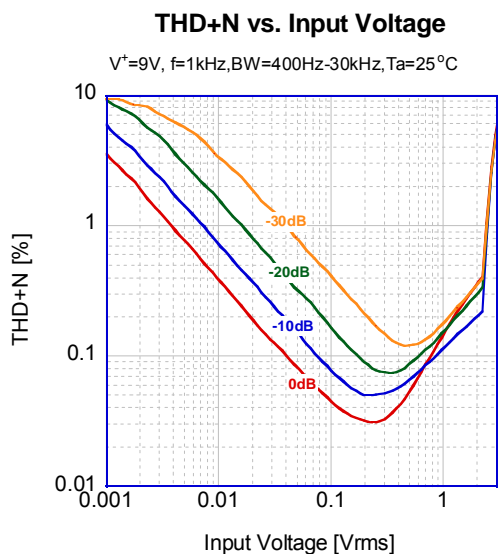

TYPICAL CHARACTERISTICS

Gain vs. Frequency

$V^+ = 9V, V_{in} = 100mV_{rms}, V_{ol} = 0dB$

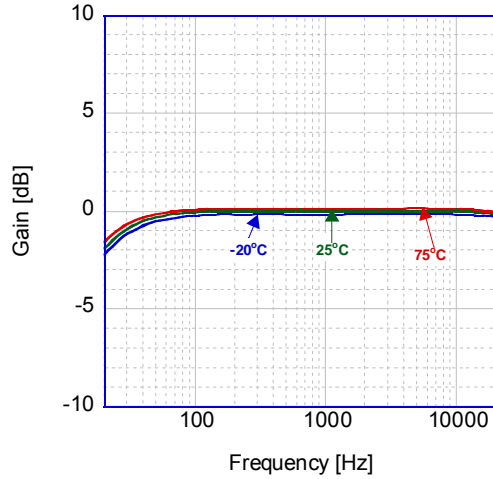

AGC Characteristics

$V^+ = 9V, f = 1kHz, T_a = 25^\circ C$

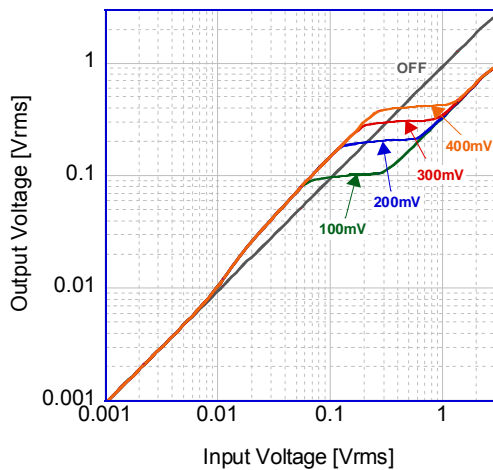

AGC Characteristics

$V^+ = 9V, f = 1kHz, AGC\ Level = 100mV$

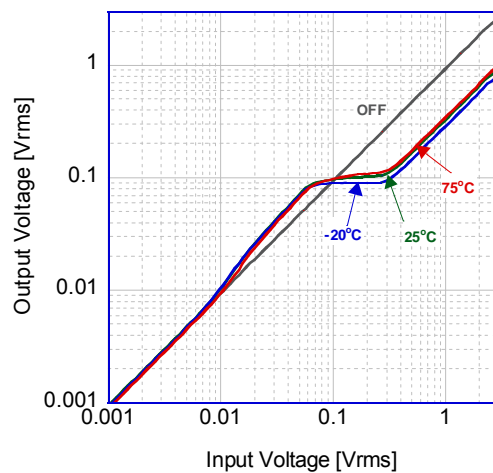

Gain vs. Frequency (Tone)

$V^+ = 9V, V_{in} = 100mV_{rms}, T_a = 25^\circ C$

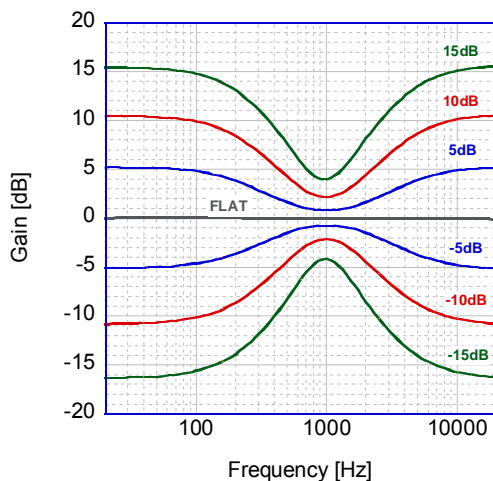

Gain vs. Frequency (Tone)

$V_{cc} = 9V, V_{in} = 100mV_{rms}, Tone = +15/-15dB$

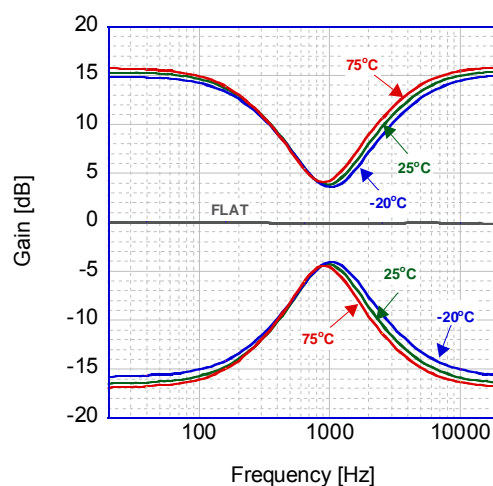

TYPICAL CHARACTERISTICS

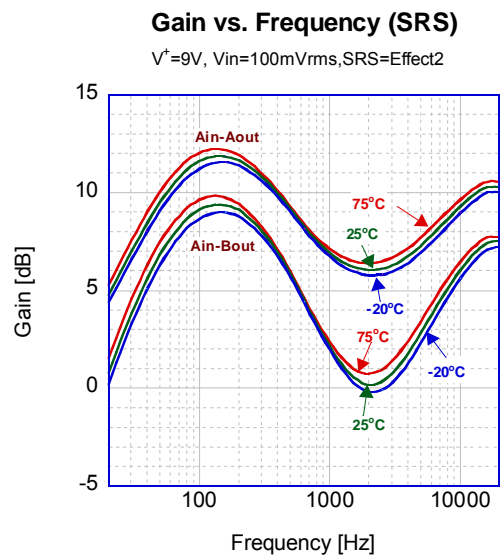
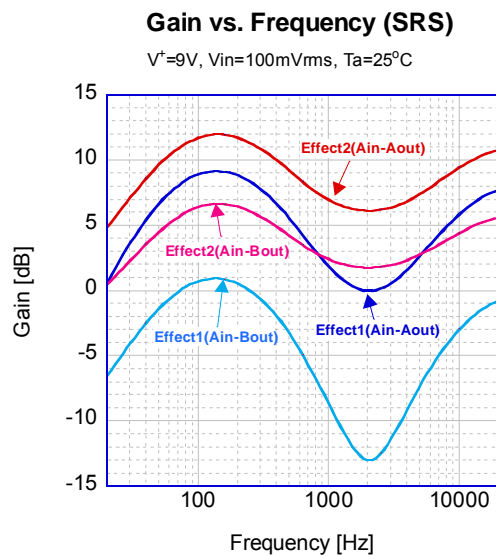
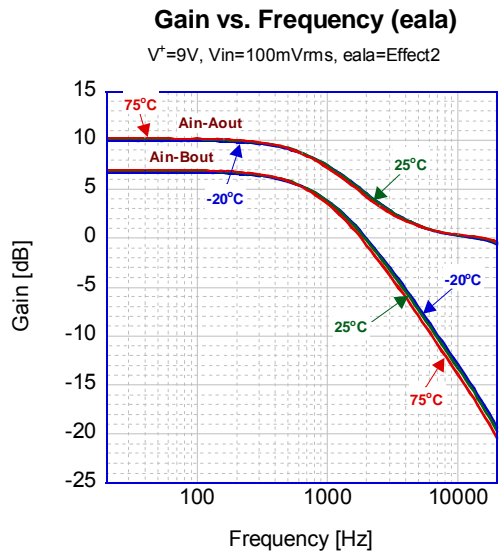
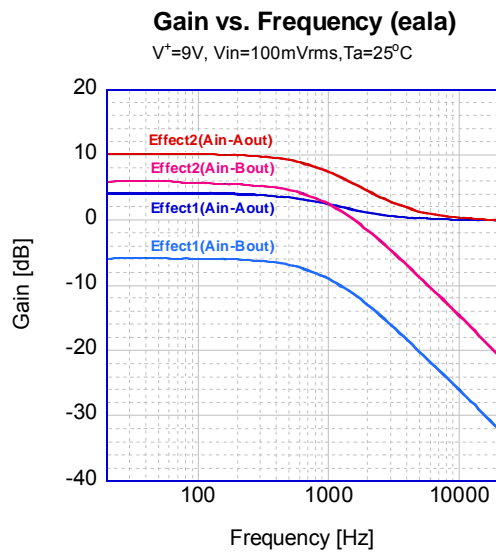
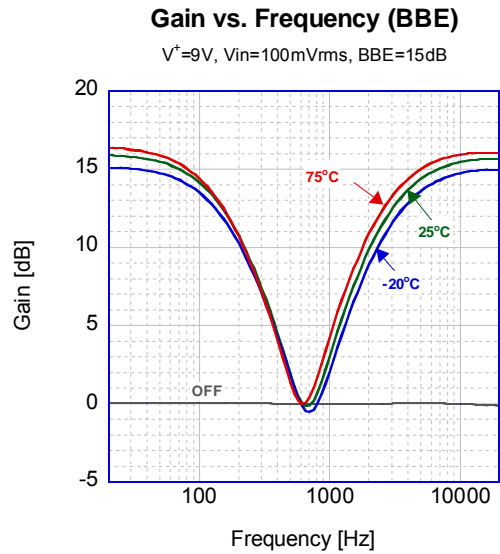
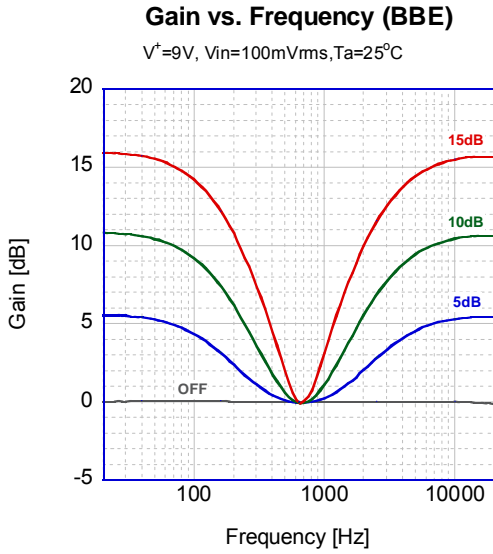

TYPICAL CHARACTERISTICS

Gain vs. Frequency (Simulated Surround)

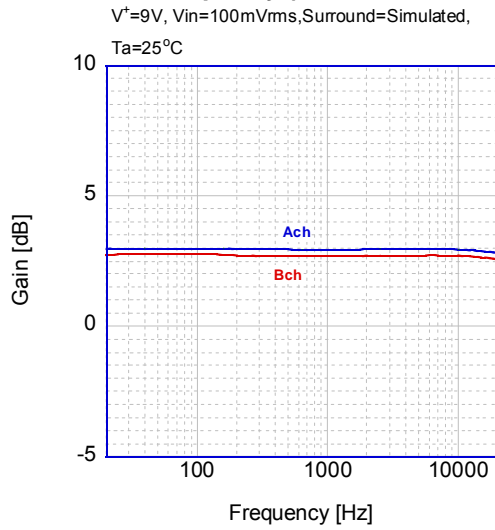

Phase vs. Frequency (Simulated Surround)

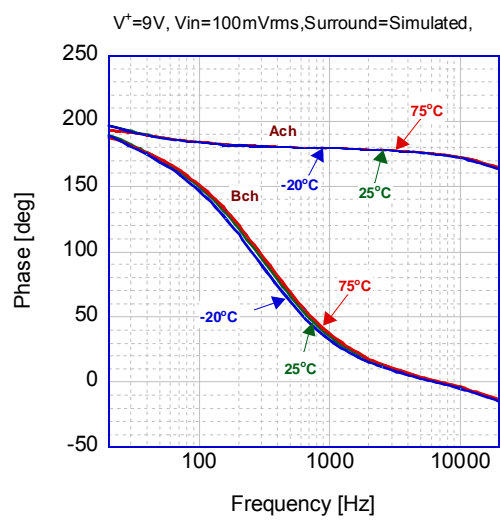

Gain vs. Frequency (ealaBass)

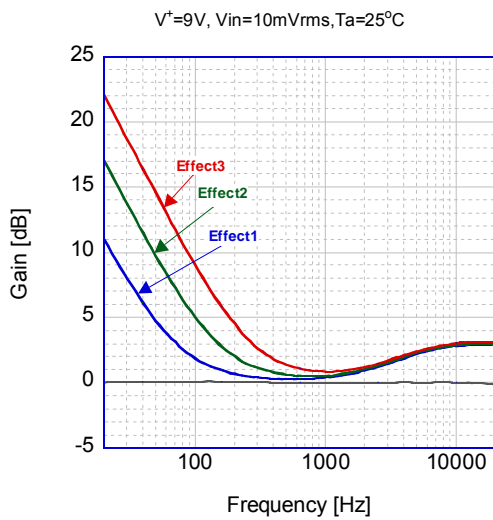

Gain vs. Frequency (ealaBass)

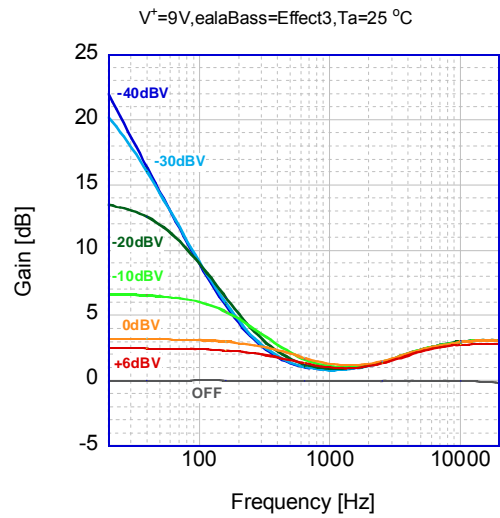

Gain vs. Frequency (ealaBass)

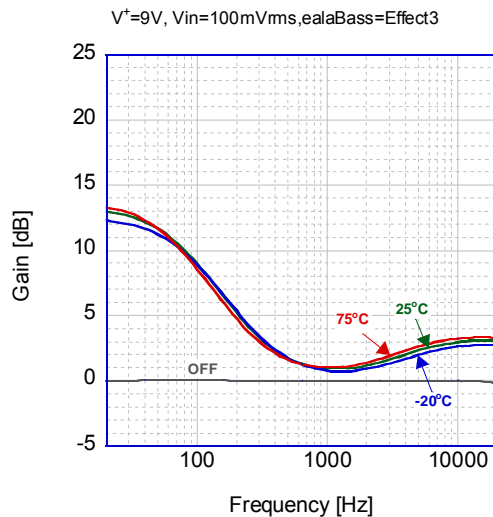

■NOTE

1) The SRS technology right incorporated in the **NJW1177** is owned by SRS Labs, a U.S. Corporation and licensed to New Japan Radio Co., Ltd. SRS is protected under U.S. and foreign patents issued and/or pending. SRS and the , are trademarks of SRS Labs, Inc. in the United States and selected foreign countries. Neither the purchase of the **NJW1177**, nor the corresponding sale of audio enhancement equipment conveys the right to sell commercialized recording made with any SRS technology.

SRS Labs requires that all users of the **NJW1177** must enter into a license agreement directly with SRS Labs if the royalty is not included in the purchase price. SRS Labs also requires any users to comply with all rules and regulations as outlined in the SRS Trademark Usage Manual.

For further information, please contact:

SRS Labs, Inc.

2909 Daimler Street, Santa Ana, CA 92705 USA

Tel : (949)442-1070

Fax: : (949)852-1099

www.srslabs.com

2) The **NJW1177** is manufactured by New Japan Radio Co., Ltd. under license from BBE Sound Inc. BBE is a registered trademark of BBE Sound Inc.

A license from BBE Sound Inc. is required before the **NJW1177** can be purchased from New Japan Radio Co., Ltd.

BBE Sound, Inc.

5381 Production Drive

Huntington Beach, CA 92649

Tel:(714)897-6766

Fax:(714)896-0736

[CAUTION]

The specifications on this databook are only given for information , without any guarantee as regards either mistakes or omissions. The application circuits in this databook are described only to show representative usages of the product and not intended for the guarantee or permission of any right including the industrial rights.