

DUAL DMOS FULL BRIDGE STEPPER MOTOR DRIVER

■ GENERAL DESCRIPTION

The NJW4382 is a high efficiency bipolar drive stepper motor driver IC, which controls steps and direction by "Phase & I0/I1" input. Stepping resolution is available with "Full", "Half", "Modified half" and "Quarter" by using combination of I0 and I1.

It has characteristics such as low quiescent current, high output current, 40V tolerance and low ON resistance output.

Internal protection circuits are Under Voltage Lockout (UVLO), Thermal Shutdown (TSD) and Over Current Protection (OCP).

Therefore, the NJW4382 is suitable for various stepper motors.

■ PACKAGE OUTLINE

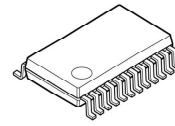

NJW4382VP1

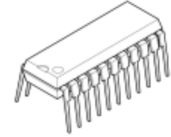

NJW4382L

■ FEATURES

- Supply Voltage $V_{MM}=8$ to 36V
- Output Current $I_o=900\text{mA}$ (DC)
 $I_o=1500\text{mA}$ (Peak)
- Low ON Resistance Output $R_{O(H+L)}=1.0\Omega$ typ. (High side + Low side)
- Input Control Method Phase & I0/I1
- Constant Current Control Circuit
 - Two Bit Current Level Selection (100%, 71%, 38%, 0%)
 - Auto Current Decay Function (ACD)
- External VR Input
- Low Quiescent Current
- Standby Function
- Protection Circuit OCP, UVLO, TSD
- Alarm Output Function for OCP or TSD circuit
- BCD Technology
- Package HTSSOP24-P1, SDIP22

■ BLOCK DIAGRAM

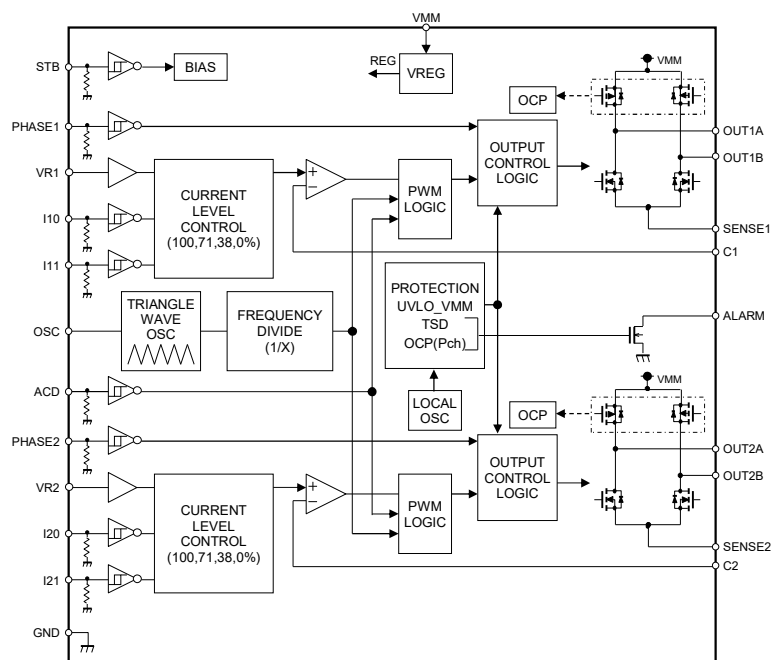

NJW4382

■ PIN CONFIGURATION

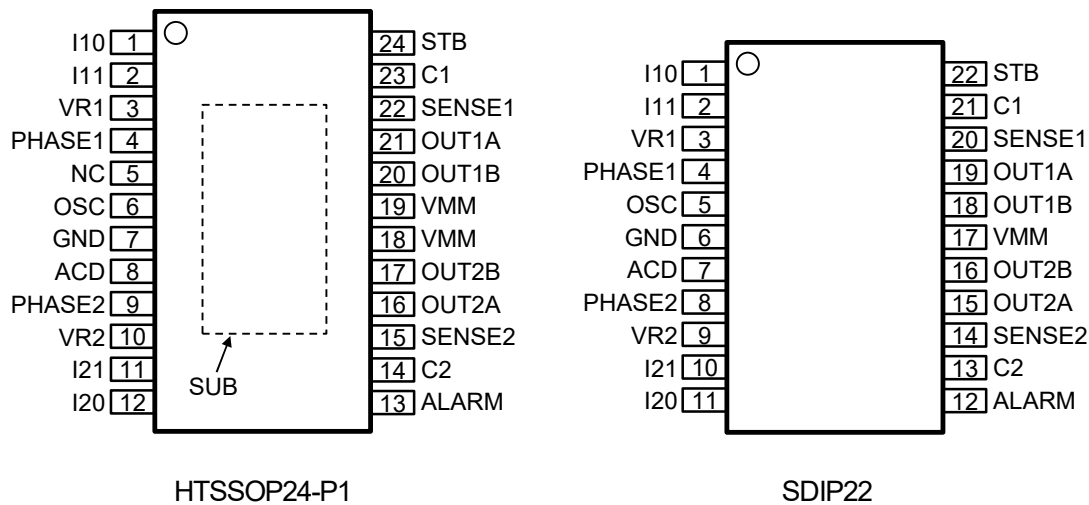

■ PIN DESCRIPTION

PIN No.		PIN NAME	I/O	FUNCTION	NOTES
HTSSOP24	SDIP22				
1	1	I10	I	1ch Maximum Output Current Setting Input Pin	Set maximum output current of 1ch by combination with I10/ I11. I10/ I11: L/L=100%, H/L=71%, L/H=38%, H/H=0%
2	2	I11	I		
3	3	VR1	I	1ch Reference Voltage Input Pin	Connect to an arbitrary reference voltage source for setting maximum output current of 1ch.
4	4	PHASE1	I	1ch Phase Direction Input Pin	H: OUT1A=H/OUT1B=L, L: OUT1A=L/OUT1B=H
5	-	NC	-	No Connection	Not Internally Connected
6	5	OSC	-	OSC Pin	Connect a capacitor and a resistor for setting oscillating frequency of PWM.
7	6	GND	-	Logic Ground Pin	Logic Ground
8	7	ACD	I	Auto Current Decay Setting Pin	L=Auto Current Decay, H=Slow Decay
9	8	PHASE2	I	2ch Phase Direction Input Pin	H: OUT2A=H/OUT2B=L, L: OUT2A=L/OUT2B=H
10	9	VR2	I	2ch Reference Voltage Input Pin	Connect to an arbitrary reference voltage source for setting maximum output current of 2ch.
11	10	I21	I	2ch Maximum Output Current Setting Input Pin	Set maximum output current of 2ch by combination with I20/ I21. I20/ I21: L/L=100%, H/L=71%, L/H=38%, H/H=0%
12	11	I20	I		
13	12	ALARM	O	Alarm Output Pin	When the internal OCP or TSD operation is detected, the output is L.
14	13	C2	I	2ch Constant Current Detection Pin	Connect to the SENSE2 pin directly or through RC filter.
15	14	SENSE2	O	2ch Current Sensing Resistor Connection Pin	Connect a resistor for current sensing of 2ch. When not using, connect to GND.
16	15	OUT2A	O	2ch Output Pin A	-
17	16	OUT2B	O	2ch Output Pin B	-
18,19	17	VMM	-	Power Supply Pin	Connect to power supply. (Both pins must be connected together externally on HTSSOP24)
20	18	OUT1B	O	1ch Output Pin B	-
21	19	OUT1A	O	1ch Output Pin A	-
22	20	SENSE1	O	1ch Current Sensing Resistor Connection Pin	Connect a resistor for current sensing of 1ch. When not using, connect to GND.
23	21	C1	I	1ch Constant Current Detection Pin	Connect to the SENSE1 pin directly or through RC filter.
24	22	STB	I	Standby Pin	H=Normal operation, L=Standby
SUB	-	-	-	Back side thermal PAD	The PAD is connected to the internal GND. It must be set to open or connected to GND.

■ ABSOLUTE MAXIMUM RATINGS

(Ta=25°C)

PARAMETER	SYMBOL	RATINGS	UNIT	NOTES
Supply Voltage	V_{MM}	40	V	VMM Pin
Motor Output Current (DC)	I_O	0.9	A	Per 1 channel
Motor Output Current (Peak)	I_{OPEAK}	1.5	A	Per 1 channel
Logic Input Pin Voltage	V_{IND}	6	V	PHASE1, PHASE2, I10, I11, I20, I21, STB, ACD Pin
Analog Input Pin Voltage	V_{INA}	6	V	VR1, VR2, C1, C2 Pin
SENSE Pin Voltage	V_{SENSE}	6	V	SENSE1, SENSE2 Pin
ALARM Output Pin Voltage	V_{ALARM}	6	V	ALARM Pin
ALARM Output Pin Current	I_{ALARM}	20	mA	ALARM Pin
Operating Ambient Temperature	T_{opr}	-40 to +85	°C	-
Junction Temperature	T_j	-40 to +150	°C	-
Storage Temperature	T_{stg}	-50 to +150	°C	-
Power Dissipation (HTSSOP24)	P_D	1200	mW	Mounted on 2Layers PCB (*1)
		1800		Mounted on 4Layers PCB (*2)
		3700		Mounted on 4Layers PCB (*3)
Power Dissipation (SDIP22)	P_D	1200	mW	Device itself
		1700		Mounted on 2Layers PCB (*4)
		2400		Mounted on 2Layers PCB (*5)

(*1): Mounted on glass epoxy board based on EIA/JEDEC. (114.5×101.5×1.6mm, FR-4, 2Layers, connected exposed PAD)

(*2): Mounted on glass epoxy board based on EIA/JEDEC. (114.5×101.5×1.6mm, FR-4, 4Layers, inner Cu area : 99.5×99.5mm)

(*3): Mounted on glass epoxy board based on EIA/JEDEC. (114.5×101.5×1.6mm, FR-4, 4Layers, inner Cu area : 99.5×99.5mm, in addition thermal via holes, connected exposed PAD)

(*4): Mounted on glass epoxy board based on EIA/JEDEC. (114.5×101.5×1.6mm, FR-4, 2Layers)

(*5): Mounted on NJRC original board. (114.5×101.5×1.6mm, FR-4, 2Layers, 2Layer side Cu area: 99.5×99.5mm)

■ RECOMMENDED OPERATING CONDITIONS

(Ta=25°C)

PARAMETER	SYMBOL	TEST CONDITIONS	MIN.	TYP.	MAX.	UNIT
Supply Voltage	V_{MM}		8	-	36	V
Logic Input Pin Voltage	V_{IND}		-	-	5.5	V
Analog Input Pin Voltage	V_{INA}		-	-	5.5	V
ALARM Output Pin Voltage	V_{ALARM}		-	-	5.5	V
OSC Pin Oscillating Frequency	f_{SAWOSC}		-	-	150	kHz

■ PIN OPERATING CONDITIONS

(V_{MM}=24V, Ta=25°C)

PARAMETER	SYMBOL	TEST CONDITIONS	MIN.	TYP.	MAX.	UNIT
■ Logic Input Pin (PHASE1, PHASE2, I10, I11, I20, I21, STB, ACD Pin)						
H Level Input Voltage	V_{HIND}		2.0	-	5.5	V
L Level Input Voltage 1	V_{LIND1}	PHASE1, PHASE2, I10, I11, I20, I21, ACD Pin	0	-	0.8	V
L Level Input Voltage 2	V_{LIND2}	STB Pin	0	-	0.6	V
Input Pulse Width	t_s	Except STB Pin	2	-	-	μs
Setup Time	t_{SET}	STB Pin	200	-	-	μs
■ Motor Output Pin (OUT1A, OUT1B, OUT2A, OUT2B Pin)						
Motor Output Pin Voltage	V_O		-	-	36	V
■ Sense Pin (SENSE1, SENSE2 Pin)						
Sense Pin Voltage	V_{SENSE}		-	-	1	V

NJW4382

■ ELECTRICAL CHARACTERISTICS

($V_{MM}=24V$, $V_{STB}=5V$, $V_{SENSE1}=V_{SENSE2}=0V$, $T_a=25^{\circ}C$)

PARAMETER	SYMBOL	TEST CONDITIONS	MIN.	TYP.	MAX.	UNIT
■ GENERAL						
Quiescent Current	I_{MM}	$V_{MM}=24V$, except I_{IH}	-	3.0	4.8	mA
Standby Current	I_{STB}	$V_{STB}=0V$	-	13	20	μA
■ LOGIC BLOCK (PHASE1, PHASE2, I10, I11, I20, I21, STB, ACD Pin)						
Input Hysteresis Voltage 1	$V_{HYSIND1}$	PHASE1, PHASE2, I10, I11, I20, I21, ACD Pin	-	0.15	-	V
Input Hysteresis Voltage 2	$V_{HYSIND2}$	STB Pin	-	0.2	-	V
H Level Input Current	I_{IHD}	$V_{IND}=5.0V$, per 1 input	33	50	100	μA
L Level Input Current	I_{ILD}	$V_{IND}=0V$, per 1 input	-200	-	200	nA
Input Pull Down Resistance	R_{INDN}		-	100	-	k Ω
■ ANALOG BLOCK 1 (OSC Pin)						
OSC Pin Charge Current	I_{CHGOSC}		0.7	1.6	2.5	mA
OSC Pin Discharge Current	$I_{DCHGOSC}$		20	50	80	μA
OSC Oscillating Frequency 1	$f_{SAWOSC1}$	$C_{OSC}=1000pF$	10	22	35	kHz
OSC Oscillating Frequency 2	$f_{SAWOSC2}$	$C_{OSC}=2200pF$, $R_{OSC}=22k\Omega$	20	30	50	kHz
■ ANALOG BLOCK 2 (VR1, VR2, C1, C2 Pin)						
VR Pin Input Current	I_{VR}	$V_{VR}=5V$, per 1 input	-200	-	200	nA
C Pin Threshold Voltage 1 (100%)	V_{CDET1}	$V_{VR}=5V$, I10=I20=L, I11=I21=L	460	500	540	mV
C Pin Threshold Voltage 2 (71%)	V_{CDET2}	$V_{VR}=5V$, I10=I20=H, I11=I21=L	315	355	395	mV
C Pin Threshold Voltage 3 (38%)	V_{CDET3}	$V_{VR}=5V$, I10=I20=L, I11=I21=H	150	190	230	mV
C Pin Input Current	I_{IC}	$V_C=0V$, per 1 input	-200	-	200	nA
Blanking Time1	t_{B1}	$C_{OSC}=1000pF$	-	1.3	-	μs
Blanking Time2	t_{B2}	$C_{OSC}=2200pF$, $R_{OSC}=22k\Omega$	-	2.6	-	μs
■ ALARM OUTPUT BLOCK						
L Output Voltage	V_{ALARM}	$I_{ALARM}=10mA$	-	0.2	0.3	V
ALARM Pin Leak Current	$I_{ALARMLEAK}$	$V_{ALARM}=5.5V$	-	-	1.0	μA
■ MOTOR OUTPUT BLOCK						
High Side Output ON Resistance	R_{OH}	$I_o=900mA$	-	0.5	0.7	Ω
Low Side Output ON Resistance	R_{OL}	$I_o=900mA$	-	0.5	0.7	Ω
R_{OH} Temperature coefficient	$\Delta R_{OH}/\Delta T_j$	$I_o=900mA$, $T_j=-40$ to $150^{\circ}C$	-	1.8	-	m $\Omega/^{\circ}C$
R_{OL} Temperature coefficient	$\Delta R_{OL}/\Delta T_j$	$I_o=900mA$, $T_j=-40$ to $150^{\circ}C$	-	1.5	-	m $\Omega/^{\circ}C$
High Side Leak Current	I_{OLEAKH}	$V_{MM}=36V$, $V_o=0V$, $V_{STB}=0V$	-	-	1.0	μA
Low Side Leak Current	I_{OLEAKL}	$V_{MM}=36V$, $V_o=36V$, $V_{STB}=0V$	-	-	1.0	μA
High Side Reverse Voltage	V_{ORH}	$I_o=-900mA$	-	0.85	1.5	V
Low Side Reverse Voltage	V_{ORL}	$I_o=-900mA$	-	0.85	1.5	V
SENSE Pin Leak Current	$I_{SENSELEAK}$	$V_{SENSE}=1V$ (SENSE→GND), $V_{STB}=0V$	-	-	5.0	μA
Output Turn On Time	tpd1		-	850	-	ns
Output Turn Off Time	tpd2		-	150	-	ns
Dead Time	td		-	700	-	ns

■ ELECTRICAL CHARACTERISTICS

($V_{MM}=24V$, $V_{STB}=5V$, $V_{SENSE1}=V_{SENSE2}=0V$, $T_a=25^{\circ}C$)

PARAMETER	SYMBOL	TEST CONDITIONS	MIN.	TYP.	MAX.	UNIT
■ UNDER VOLTAGE LOCK OUT BLOCK						
UVLO Operating Voltage	V_{DUVLO}	V_{MM} decreasing	6.6	7.1	7.6	V
UVLO Recovery Voltage	V_{RUVLO}	V_{MM} increasing	6.8	7.3	7.8	V
UVLO Hysteresis Voltage	ΔV_{UVLO}		0.1	0.2	0.3	V
■ THERMAL SHUTDOWN BLOCK						
Thermal Shutdown Operating Temperature	T_{DTSD}		-	170	-	$^{\circ}C$
Thermal Shutdown Recovery Temperature	T_{RTSD}		-	140	-	$^{\circ}C$
Thermal Shutdown Hysteresis	ΔT_{TSD}		-	30	-	$^{\circ}C$
■ OVER CURRENT PROTECTION BLOCK						
OCP Detection Current	I_{OCP}		1.5	2.5	-	A
OCP Delay Time	t_{OCP}		-	400	-	ns
OCP Recovery Trigger Interval	t_{OCPR}		-	30	-	μs
OCP Detection Count Period	t_{OCPDET}		-	500	-	μs

■ THERMAL CHARACTERISTICS

■ HTSSOP24-P1

PARAMETER	SYMBOL	TEST CONDITIONS	MIN.	TYP.	MAX.	UNIT
Junction - Ambient Thermal Resistance 1	θ_{ja1}	Mounted on glass epoxy board based on EIA/JEDEC. (114.5×101.5×1.6mm, FR-4, 2Layers, connected exposed PAD)	-	-	104.2	$^{\circ}CW$
Junction - Case Surface characterization parameter 1	ψ_{jc1}	Mounted on glass epoxy board based on EIA/JEDEC. (114.5×101.5×1.6mm, FR-4, 2Layers, connected exposed PAD)	-	7.2	-	$^{\circ}CW$
Junction - Ambient Thermal Resistance 2	θ_{ja2}	Mounted on glass epoxy board based on EIA/JEDEC. (114.5×101.5×1.6mm, FR-4, 4Layers, inner Cu area : 99.5×99.5mm, not connected exposed PAD)	-	-	69.4	$^{\circ}CW$
Junction - Case Surface characterization parameter 2	ψ_{jc2}	Mounted on glass epoxy board based on EIA/JEDEC. (114.5×101.5×1.6mm, FR-4, 4Layers, inner Cu area : 99.5×99.5mm, not connected exposed PAD)	-	7.6	-	$^{\circ}CW$
Junction - Ambient Thermal Resistance 3	θ_{ja3}	Mounted on glass epoxy board based on EIA/JEDEC. (114.5×101.5×1.6mm, FR-4, 4Layers, inner Cu area : 99.5×99.5mm, in addition thermal via holes, connected exposed PAD)	-	-	33.8	$^{\circ}CW$
Junction - Case Surface characterization parameter 3	ψ_{jc3}	Mounted on glass epoxy board based on EIA/JEDEC. (114.5×101.5×1.6mm, FR-4, 4Layers, inner Cu area : 99.5×99.5mm, in addition thermal via holes, connected exposed PAD)	-	2.7	-	$^{\circ}CW$

■ SDIP22

PARAMETER	SYMBOL	TEST CONDITIONS	MIN.	TYP.	MAX.	UNIT
Junction - Ambient Thermal Resistance 1	θ_{ja1}	Mounted on glass epoxy board based on EIA/JEDEC. (114.5×101.5×1.6mm, FR-4, 2Layers)	-	-	73.5	$^{\circ}CW$
Junction - Case Surface characterization parameter 1	ψ_{jc1}	Mounted on glass epoxy board based on EIA/JEDEC. (114.5×101.5×1.6mm, FR-4, 2Layers)	-	13.7	-	$^{\circ}CW$
Junction - Ambient Thermal Resistance 2	θ_{ja2}	Mounted on NJRC original board. (114.5×101.5×1.6mm, FR-4, 2Layers, 2Layer side Cu area: 99.5×99.5mm)	-	-	52.1	$^{\circ}CW$
Junction - Case Surface characterization parameter 2	ψ_{jc2}	Mounted on NJRC original board. (114.5×101.5×1.6mm, FR-4, 2Layers, 2Layer side Cu area: 99.5×99.5mm)	-	13.1	-	$^{\circ}CW$

NJW4382

■ POWER DISSIPATION vs. AMBIENT TEMPERATURE

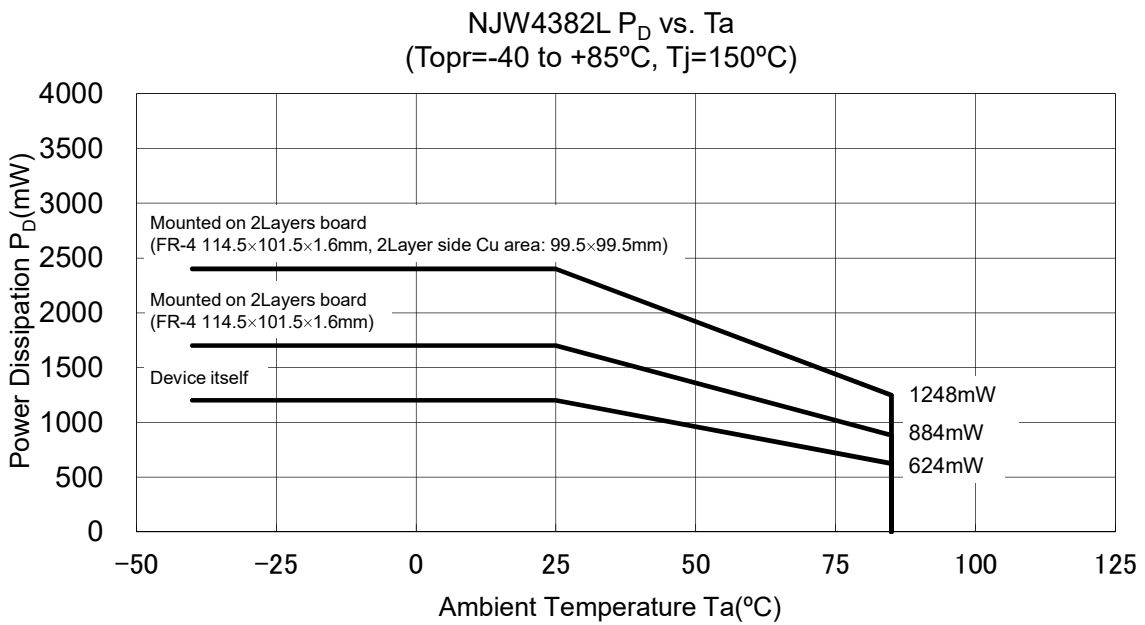
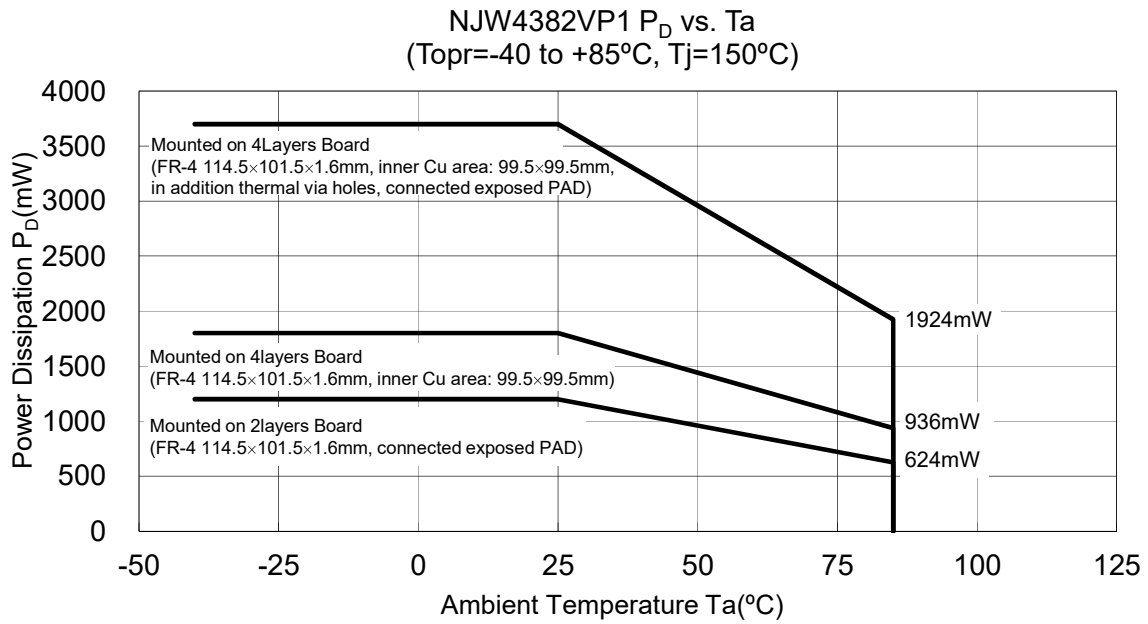

TRUTH TABLE

INPUT					OUTPUT		ALARM Output	Current Decay	OUTPUT Status	Current Level	NOTES
STB	ACD	PHASE1/2	I10/I20	I11/I21	OUT1A/2A	OUT1B/2B					
H	L	H	L	L	H	L(PWM)	H	Auto (Fast/Slow)	CW	100%	-
			H	L	H	L(PWM)				71%	-
			L	H	H	L(PWM)				38%	-
			H	H	OFF	OFF				0%	-
		L	L	L	L(PWM)	H			CCW	100%	-
			H	L	L(PWM)	H				71%	-
			L	H	L(PWM)	H				38%	-
			H	H	OFF	OFF				0%	-
	H	H	L	L	H	L(PWM)		Slow	CW	100%	-
			H	L	H	L(PWM)				71%	-
			L	H	H	L(PWM)				38%	-
			H	H	H	H				0%	-
		L	L	L	L(PWM)	H			CCW	100%	-
			H	L	L(PWM)	H				71%	-
			L	H	L(PWM)	H				38%	-
			H	H	H	H				0%	-
L	X	X	X	X	OFF	OFF	L	-	OFF	-	STANDBY
H											TSD or OCP Operation

*OFF(OUTPUT): Hi-Z State

Auto Current Decay (ACD) FUNCTION TIMING CHART

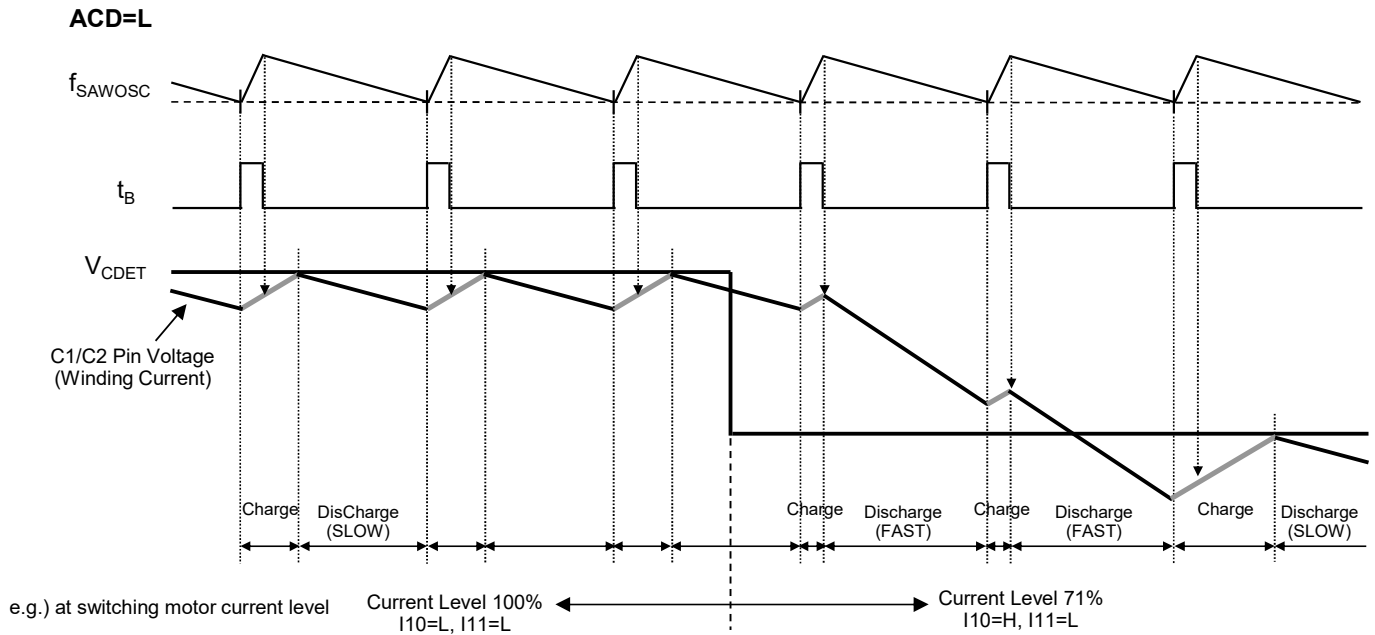

When using ACD function (ACD=L), current decay path in discharge period is determined by comparing C1/C2 pin voltage with V_{CDET} voltage after Blanking time " t_B ".

When C1/C2 pin voltage < V_{CDET} voltage, current decay path in discharge period is slow decay.

When C1/C2 pin voltage > V_{CDET} voltage, current decay path in discharge period is fast decay.

PROTECTION CIRCUIT DEFINITION

TSD Operational Definition

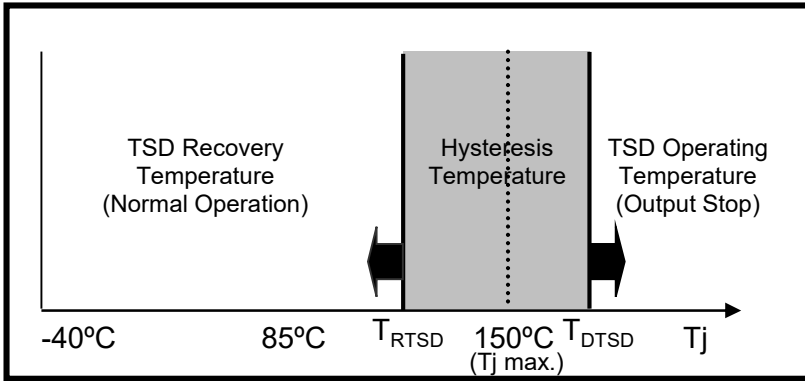

UVLO Operational Definition

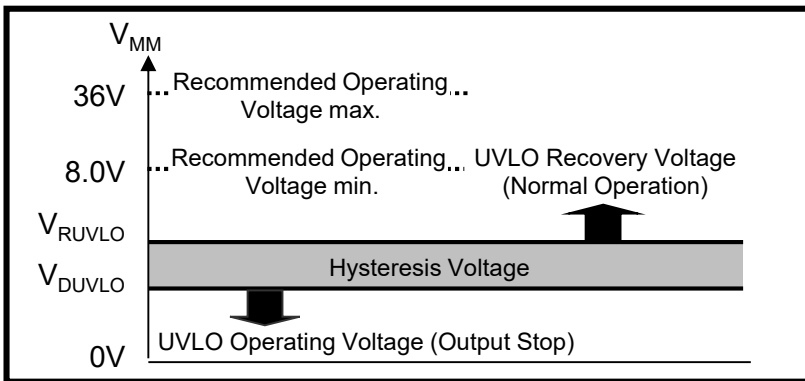

■ OCP FUNCTION TIMING CHART

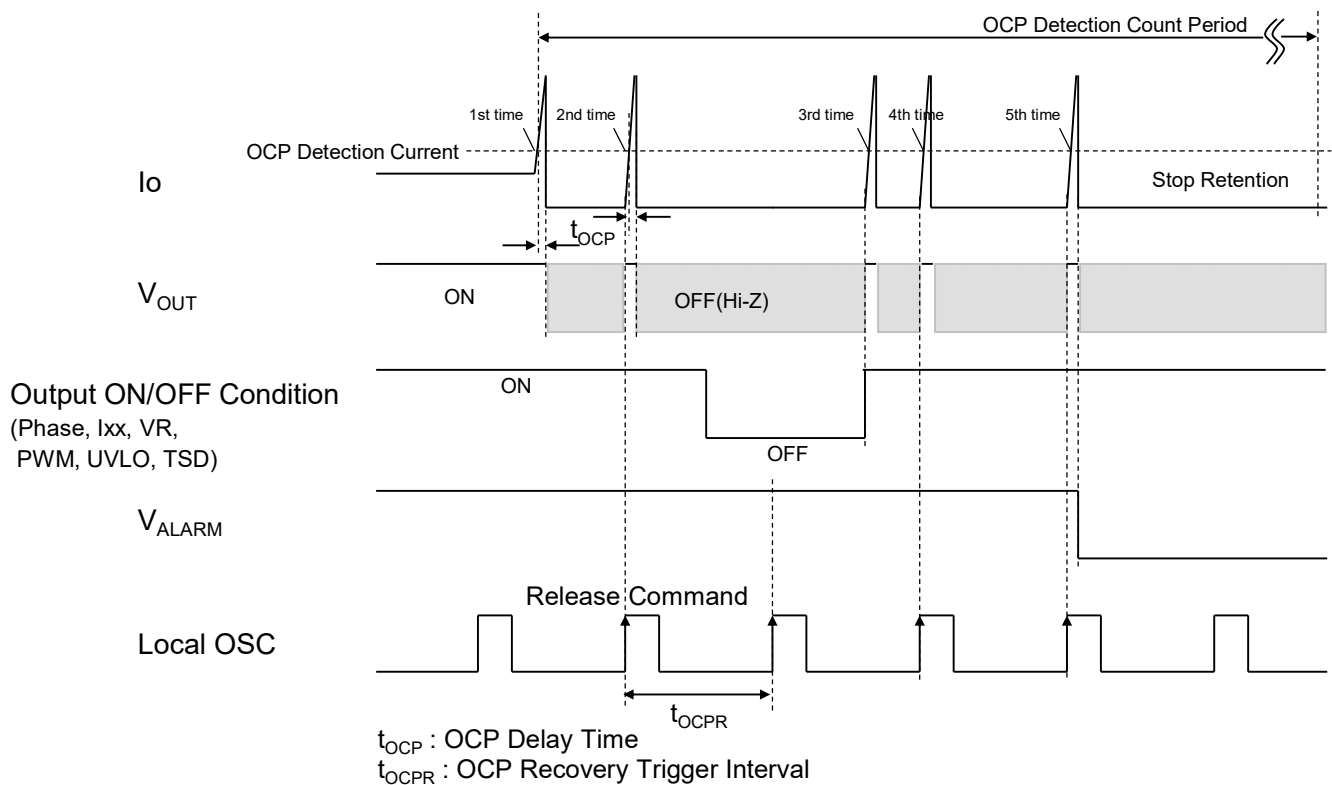

- The OCP circuit counts the OCP detection from first detection to OCP Detection Count Period.
 When OCP circuit detects five times during OCP Detection Count Period, OUT pins turn off and retain, then ALARM pin outputs ALARM signal.
 After OCP detection, the motor outputs are turned off temporarily, but motor outputs restart by trigger of internal Local OSC until five times.
 As for the timing of this restart, in the control state where the output is OFF, the output is performed after the control state in which the output is ON.
 When OCP circuit don't detect five times during OCP Detection Count Period, the OCP status returns to the normal operation by Count Canceller function.

•Count Canceller Function

NJW4382 has Count Canceller function to prevent OCP malfunction.

After 1st OCP detection,

- (1). When OCP circuit don't detect five times during OCP Detection Count Period, OCP counter is reset.
- (2). When forcibly released, the OCP counter is reset.

- Detection count, latch-off status and ALARM output can forcibly release by the following way.

- (1) Power Restart
- (2) Standby ON/OFF

■ STEPPER MOTOR DRIVE TIMING CHART

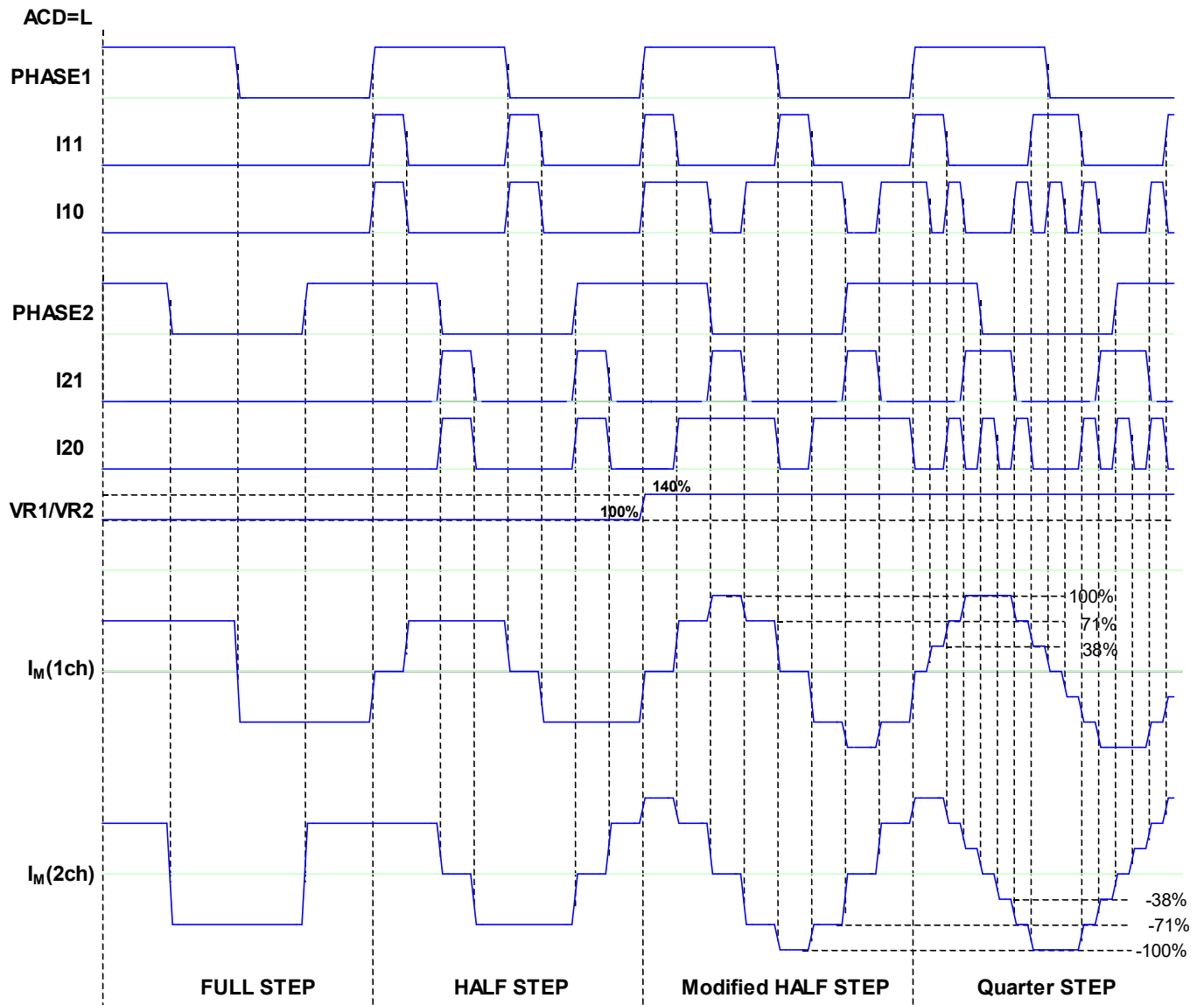

■ TYPICAL APPLICATION CIRCUIT

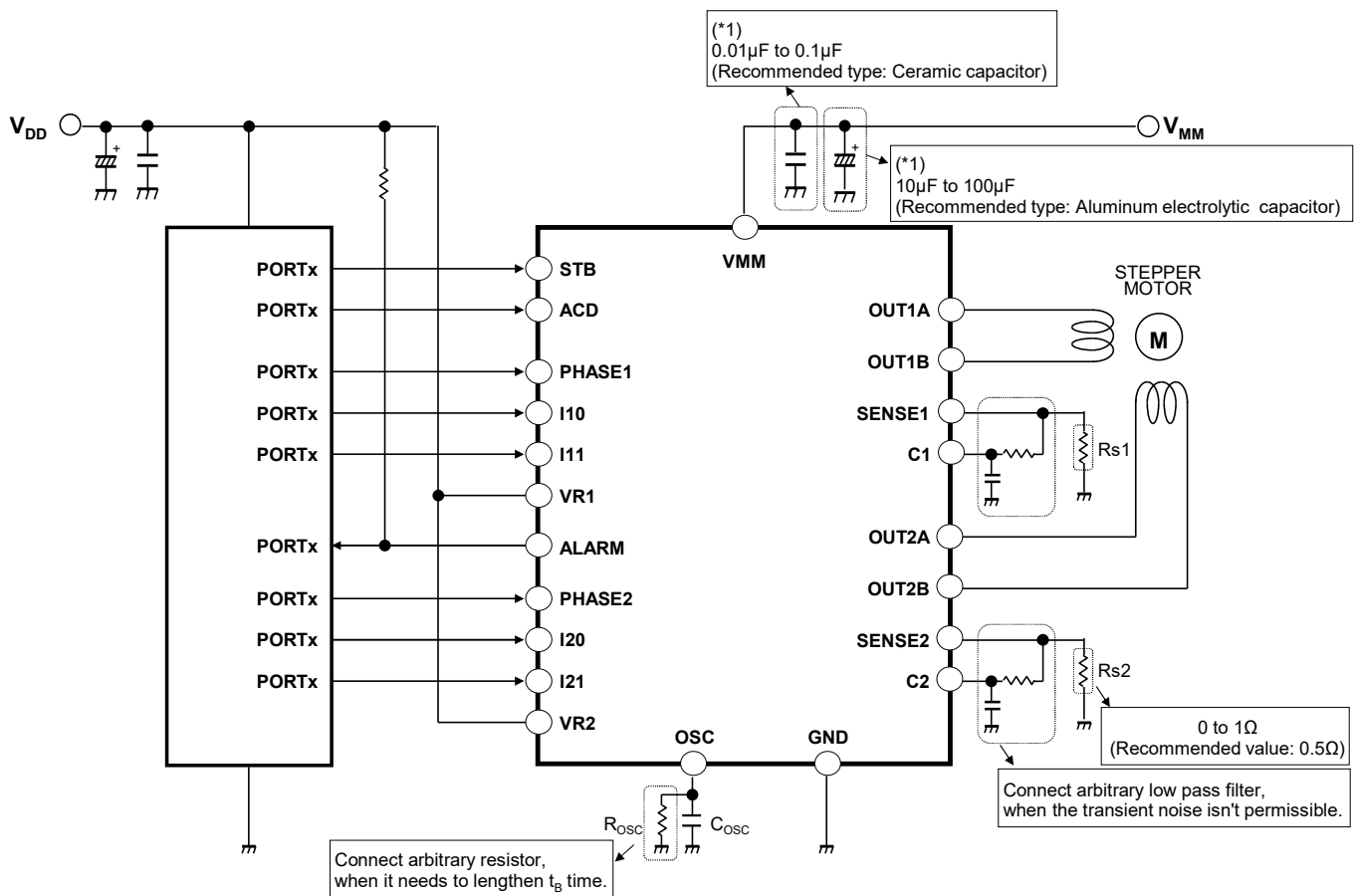

(*1)

At Fast Decay operation by phase-shift, PWM and so on, the recirculation current from motor flows through VMM pin.

Therefore, capacitors should be connected in parallel close to VMM pin in order to prevent malfunction of IC due to transient supply voltage fluctuation. The capacitance should be determined according to the stability of supply voltage. Recommend capacitances are: 0.01µF to 0.1µF of ceramic capacitor and 10µF to 100µF of Aluminum electrolytic capacitor.

The capacitors should be selected to have enough capacitance that considered characteristics of the voltage, temperature, frequency and so on.

Even if using some ICs, they can't share capacitors and each IC must connect to individual capacitors.

NJW4382

■ FUNCTION DESCRIPTION

The NJW4382 has a constant current control for the windings of a bipolar stepper motor.

The logic input block adopts PHASE&I0/I1 input control.

PHASE pins determine direction of output current, and I0 and I1 pins select current level of output current.

Therefore, it can operate "FULL STEP", "HALF STEP", "MODIFIED HALF STEP" and "QUARTER STEP".

- Basic operation pattern of H-Bridge driver (At Phase=CW)

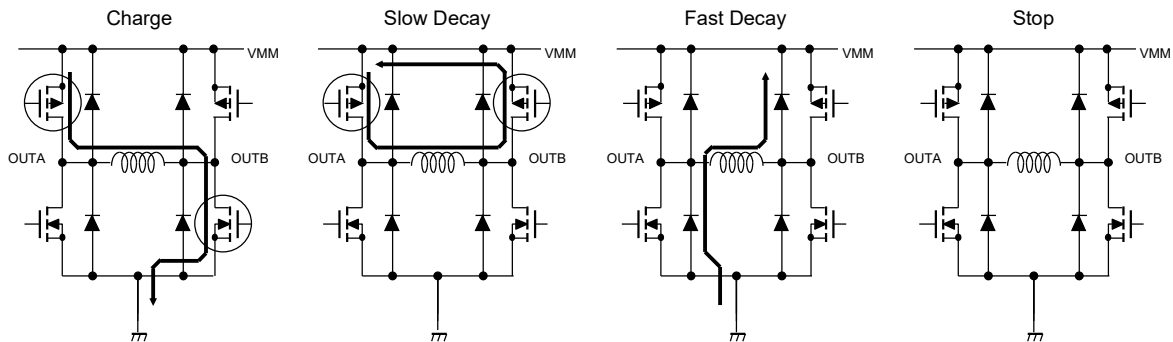

- Constant Voltage Control

Constant voltage control drives motor current which doesn't have PWM control with current detection and decided by motor voltage " V_{MM} " and motor resistance " R_M ".

$$I_o = \frac{V_{MM}}{R_M} [A]$$

In this case, OSC pin, SENSE pins and C pins connect to GND and VR pins connect to arbitrary reference voltage.

It can drive stepping resolution of "FULL STEP" and "HALF STEP" by selecting output current of 100% and 0% with I0&I1 pins.

Current recirculation by detection of motor current isn't performed, so the ACD function sets as method of recirculation at 0% output.

• Constant Current Control (PWM Chopper)

The constant current control is achieved by PWM control of low side FET switching of H-bridge.

The motor current is compared with reference voltage on the comparator block by using external current sensing resistor.

PWM logic block makes blanking time to filtering spike current in order to avoid malfunction of PWM control.

Then, it's also possible to add an external series LPF to C pin input and filter the spike current.

Moreover, PWM frequency and blanking time is able to set arbitrary by connecting with OSC pin to a capacitor or a combination of capacitor and resistor.

The value of constant current at 100% setting is decided by VR pin voltage and external sense resistor.

Besides, the status of I0 and I1 pins selects one from three different values of constant current and zero current.

Therefore, it can operate "FULL STEP", "HALF STEP", "MODIFIED HALF STEP" and "QUARTER STEP".

ACD pin selects Auto Current Decay Mode and Slow Decay Mode as the recirculation circuit at current detection.

So ACD function can also operate recirculation circuit of zero current output (Output OFF).

The value at 100% setting of constant current is calculated as follows:

$$I_{OPEAK} = 0.1 \cdot \frac{V_R}{R_S} [A]$$

e.g.) at $R_S=0.5\Omega$ and $V_R=2.5V$, I_{OPEAK} is obtained as 0.5A.

< Constant current control pattern of H-Bridge driver (At Phase=CW) >

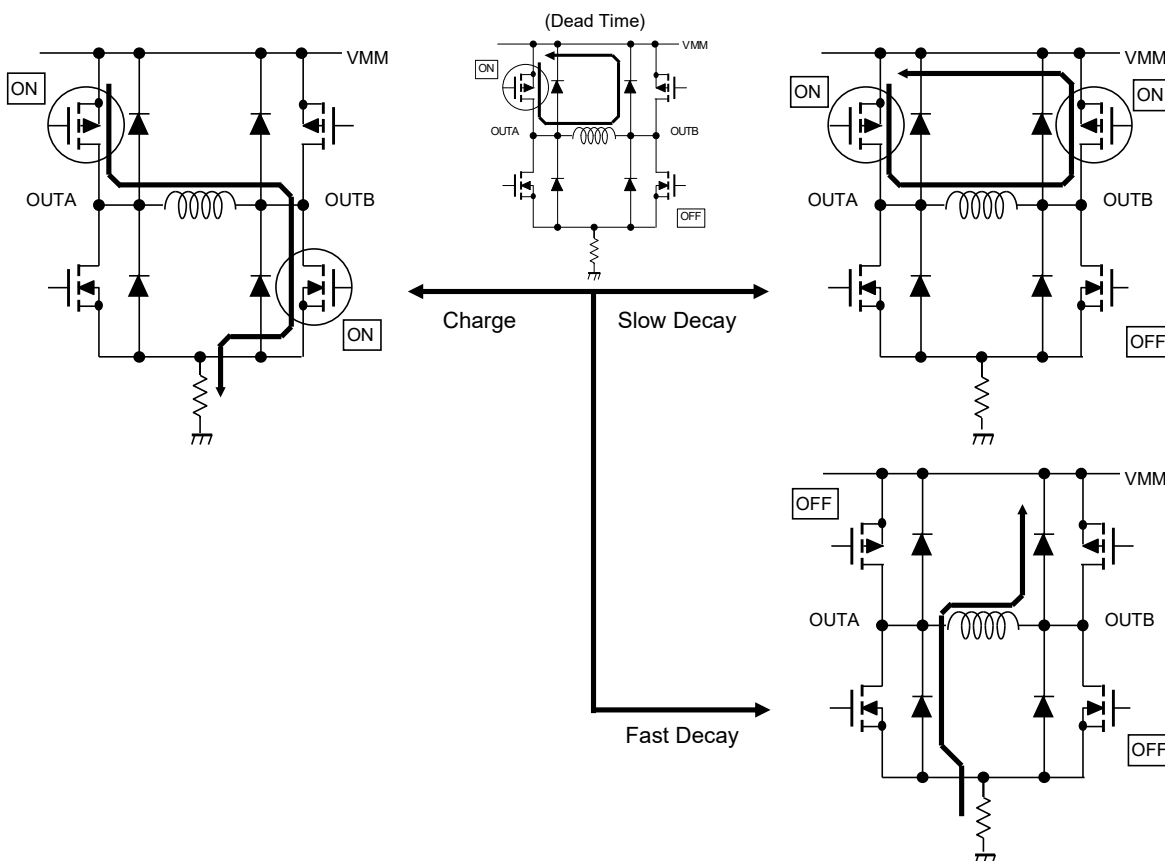

NJW4382

- PHASE (PHASE1, PHASE2 Pin)

The PHASE determines direction of output current for the windings.

When PHASE pin is H-level, output current flows to OUT1B/2B pin from OUT1A/2A pin.

When PHASE pin is L-level, output current flows to OUT1A/2A pin from OUT1B/2B pin.

Further, each PHASE pin has pull-down resistor internally.

- VR (VR Pin)

The VR voltage is reference voltage for internal comparator. It must connect arbitrary voltage.

The VR voltage is divided to voltage of 1/10 by internal resistor and the voltage is compared to SENSE pin at 100% setting of constant current.

If this pin is connected by external resistor network, the impedance has no influence between external resistance and inner resistance.

As one of the applications, if the DC voltage can be changed continuously, Micro-stepping operation can be realized.

- IO/I1 (I10, I11, I20, I21 Pin)

The I0 and I1 determine current level for the windings of motor.

The status of I0 and I1 pins selects one from three different values of constant current and zero current.

At 0% current level, the recirculation circuit for motor current is different by ACD operation.

For details, refer to the following ACD pin explanation.

Further, I0 and I1 pins have pull-down resistor internally.

ACD	INPUT		Current Decay	OUTPUT Status	Current Level
	I10/I20	I11/I21			
L	L	L	Auto (Fast/Slow)	ON(PWM)	100%
	H	L			71%
	L	H			38%
	H	H		OFF	0%
H	L	L	Slow	ON(PWM)	100%
	H	L			71%
	L	H			38%
	H	H		BRAKE	0%

- ACD (ACD Pin)

ACD pin selects Auto Current Decay Mode and Slow Decay Mode by the input voltage.

At 0% current level, the recirculation circuit for motor current is different by ACD operation.

As the current waveform image at constant current control, refer to the above-mentioned ACD FUNCTION TIMING CHART.

ACD function should be set by evaluation of actual motor current waveform.

Further, ACD pin has pull-down resistor internally.

< When ACD pin is L level >

It becomes Auto Current Decay Mode.

As Constant Current Control, current decay path in discharge period chooses slow decay path or fast decay path by detecting motor current after tb.

When motor current dragging occurs, ACD mode makes automatically fast decay path for reducing over-current.

So, this case is effective to reduce motor vibration, but it increases current ripple at fast current decay.

If the current waveform is discontinuous with sharp slope, to set high PWM frequency can improve to continual current.

Further, at 0% current level, it becomes fast decay.

e.g.) When inductance value of motor winding is relatively small.

When using step resolution less than half step as excitation mode on high speed rotation.

When switching current level frequently.

< When ACD pin is H level >

It always becomes Slow Decay Mode.

As Constant Current Control, current decay path in discharge period is slow decay only.

It reduces current ripple at all PWM operation, but it should be careful to occurrence of the motor current dragging.

At 0% current level, it is slow decay too, so it's possible to apply as brake stop.

e.g.) When inductance value of motor winding is relatively large.

When using full step resolution as excitation mode.

When using low speed rotation.

When using brake stop.

***Brake operation**

Generally, when a stepper motor stops, it causes damped vibration. (It is called settling time)

The settling time depends on the motor speed or load conditions and takes more than 100msec.

It also affects the speed enhancement of the system.

The brake function operates short circuit of the coil ends.

The short current produced by BEMF starts to flow through the coil when brake function is used.

Therefore, the rotor can stop quickly than the normal condition.

When brake operation is on "H" level, the upper side FETs of the H-bridge are turned on, and both coils ends are short circuits.

• OSC (OSC Pin)

When using constant current control, the OSC pin can set arbitrary PWM frequency and blanking time by using a combination of capacitor and resistor.

OSC pin usually connects to arbitrary capacitor for setting PWM frequency.

However, PWM frequency and blanking time become anti-proportional value, so when setting these each, OSC pin connects to arbitrary capacitor and resistor.

<When connecting to capacitor>

$$t_B [\mu s] = 1.4 \cdot 10^{-3} \cdot C_{[pF]}$$

$$f_{SAWOSC} [kHz] = 22 \cdot 10^3 \cdot \frac{1}{C_{[pF]}}$$

<When connecting to capacitor and resistor>

$$t_B [\mu s] = 0.001 \cdot C_{[pF]} \cdot R_{[k\Omega]} \cdot \text{LN} \left(\frac{1.03 - 1.58 \cdot R_{[k\Omega]}}{3.1 - 1.58 \cdot R_{[k\Omega]}} \right)$$

$$t_{FALL} [\mu s] = 0.001 \cdot C_{[pF]} \cdot R_{[k\Omega]} \cdot \text{LN} \left(\frac{3.1 + 0.05 \cdot R_{[k\Omega]}}{1.03 + 0.05 \cdot R_{[k\Omega]}} \right)$$

$$f_{SAWOSC} [kHz] = \frac{1000}{t_B [\mu s] + t_{FALL} [\mu s]}$$

<OSC pin voltage waveform>



Moreover, when not using constant current control, OSC pin must connect to GND.

In this case, OSC pin always consumes 1.6mA (typ.) as "OSC Pin Charge Current".

- SENSE (SENSE1, SENSE2 Pin), C (C1, C2 Pin)

The PWM control is performed by comparing SENSE voltage with inner comparator voltage.

In the case of the constant current control for motor, the spike current is generated with recovery diode and coil capacitance at the time of output turn-on.

In order to prevent the malfunction of the flip-flop circuit by the spike current, the blanking pulse is generated to disable the comparator operation during this pulse at the time of output turn-on.

However, if the spike current is large with motor characteristic, board layout and motor wiring, must improve noise immunity with inserting a low pass filter between SENSE resistor and comparator input pin, or setting longer blanking time.

Moreover, the value of current sensing resistance is recommended to less than 1Ω .

- STB (STB Pin)

When STB pin is on "L" level, it becomes power-saving mode and the motor outputs are turned off.

When STB pin changes from "L" level to "H" level, OCP state is initialized and it becomes normal operation mode.

Further, STB pin has pull-down resistor internally.

- ALARM (ALARM Pin)

When motor output is disabled with TSD or OCP operation, ALARM pin becomes "L" level.

ALARM pin is open drain output type. Therefore, it uses to connect pull-up resistance to outside.

When ALARM pin is unused, it sets to OPEN.

- UVLO - Under Voltage Lockout Protection

VMM pin has UVLO function for malfunction prevention at low voltage condition.

When VMM voltage is less than the UVLO operating voltage, the motor outputs are turned off.

Moreover, when VMM voltage is power-on and remarkably low voltage (less than 1.6V typ.), there is possibility that the OCP function is initialized by internal POR function.

- TSD - Thermal Shutdown Protection

When the junction temperature reaches to T_{DTSD} (170°C typ.), the motor outputs are turned off and the ALARM outputs.

When the junction temperature falls to T_{RTSD} (140°C typ.), normal operation resumes.

- OCP - Over Current Protection

The motor output current of all high side is detected for over-current protection.

Refer to "OCP FUNCTION TIMING CHART" of the above for more information.

■ TYPICAL CHARACTERISTICS

V_{MM} vs. I_{MM}

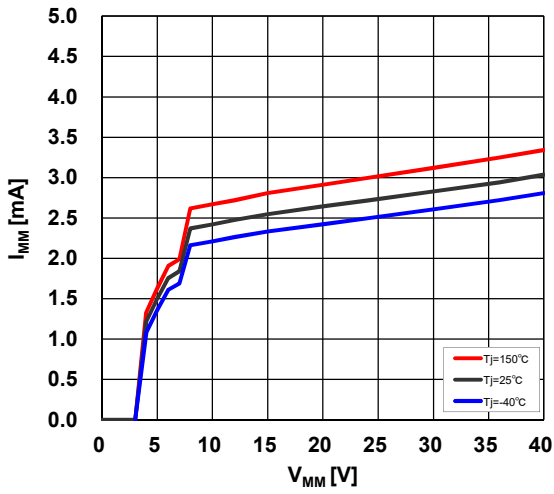

I_o vs. V_{ORH}
 $V_{MM}=24\text{V}$

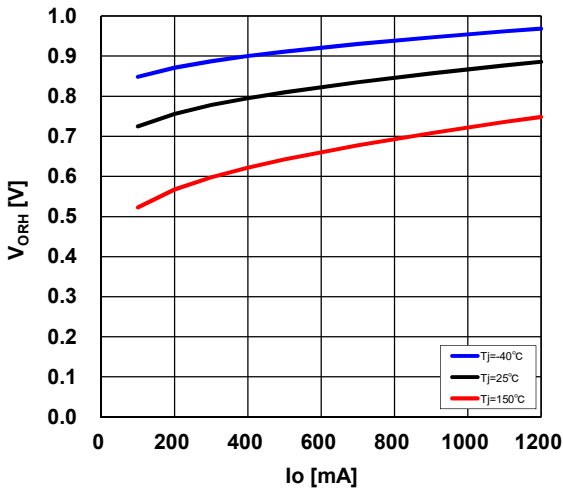

I_o vs. V_{ORL}
 $V_{MM}=24\text{V}$

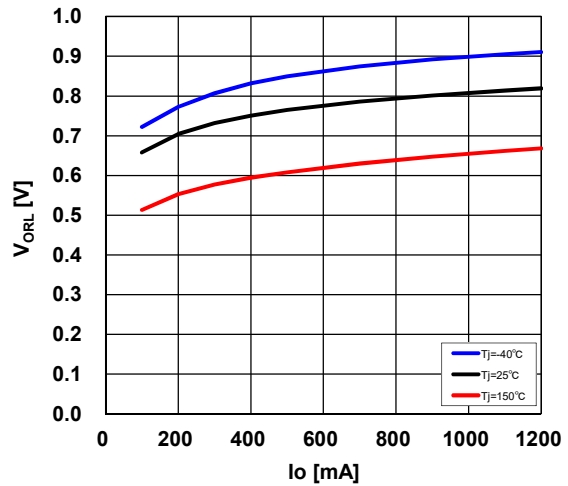

R_{OSC} , C_{OSC} vs. f_{OSC}
 $V_{MM}=24\text{V}$, $T_a=25^\circ\text{C}$

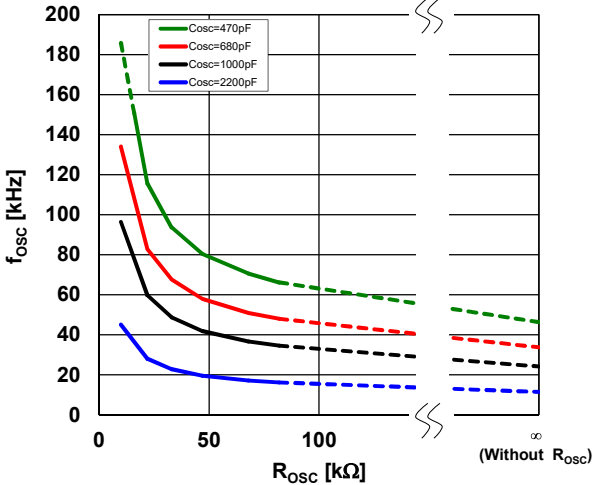

R_{OSC} , C_{OSC} vs. t_B
 $V_{MM}=24\text{V}$, $T_a=25^\circ\text{C}$

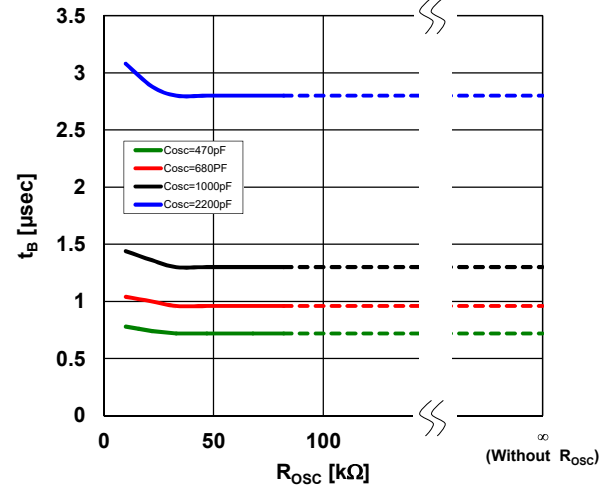

■ TYPICAL CHARACTERISTICS

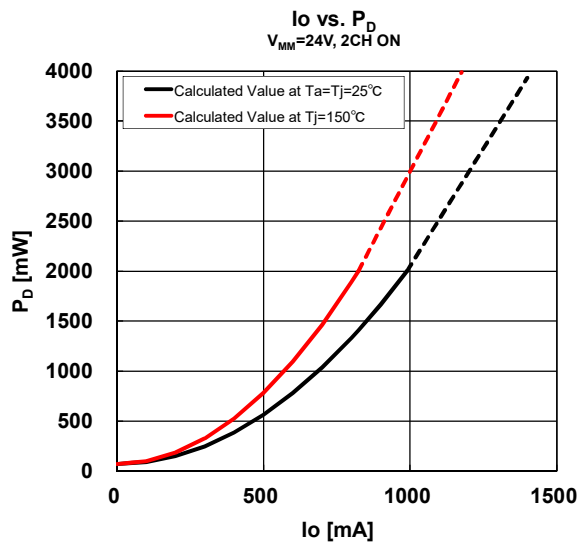
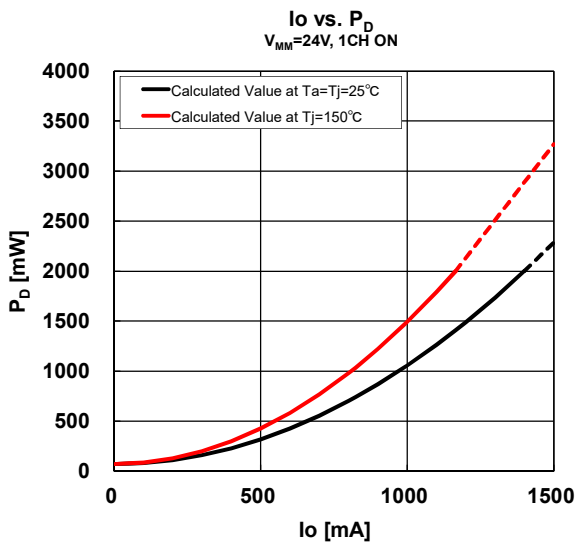
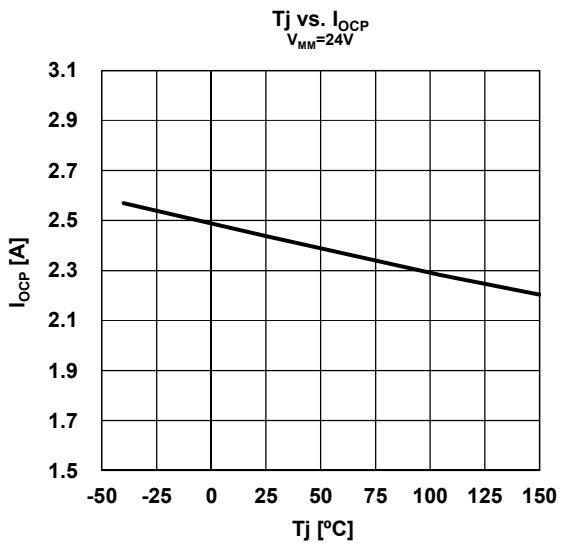
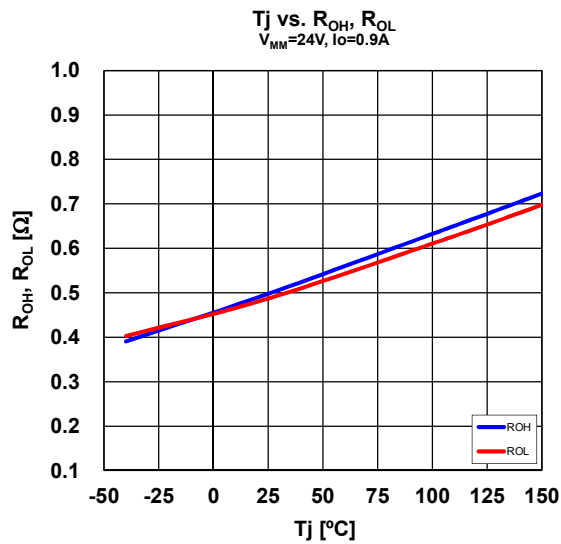
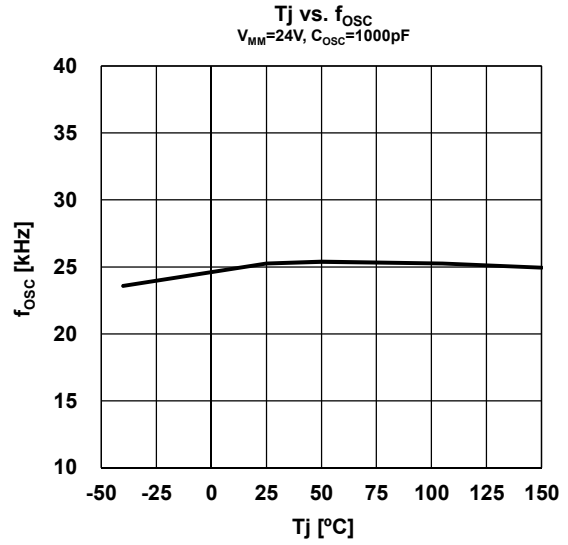
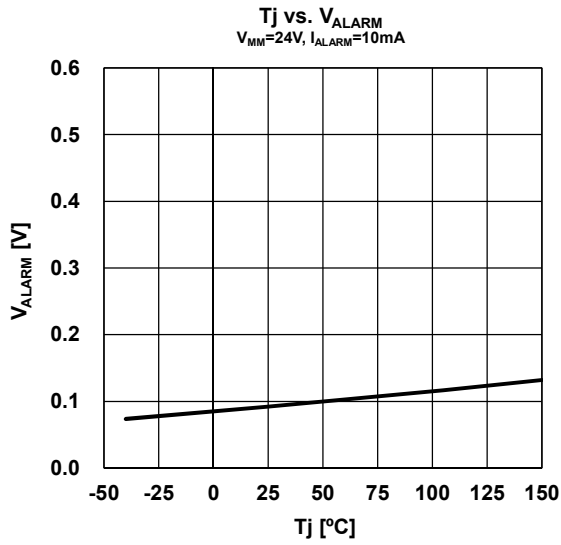

[CAUTION]

The specifications on this databook are only given for information, without any guarantee as regards either mistakes or omissions. The application circuits in this databook are described only to show representative usages of the product and not intended for the guarantee or permission of any right including the industrial rights.