

Low Operating Current Fundamental Quartz Crystal Oscillator IC

■GENERAL DESCRIPTION

The NJU6365 series is a C-MOS IC for fundamental quartz crystal oscillator that consists of an oscillation amplifier, 5-stage divider and 3-state output buffer.

The operating voltage is from 1.8V to 3.6V and high frequency-stability based on most suitable oscillation circuit including Cg, Cd and Rf.

The 5-stage divider generates only one frequency selected of $f_0, f_0/2, f_0/4, f_0/8, f_0/16$ and $f_0/32$ by internal circuits is output.

The oscillation amplifier is realized very low stand-by current using NAND circuit, and the operating current is lower than 1.5mA at 3.3V and 16MHz.

The 3-state output buffer is C-MOS compatible.

■FEATURES

- High Frequency-Stability for Operating Voltage
- Low Operating Current 1.5mA max@3.3V
- Operating Voltage 1.8 to 3.6V
- Maximum Oscillation Frequency 32MHz
- Fan-out 1.2mA min@2.5V
- 5-Stage Divider Maximum Divider $f_0/32$
- Oscillation Stop and Output Stand-by Function
- 3-State Output Buffer
- Oscillation Capacitors Cg and Cd on-Die
- Package Outline Thin-Die/Wafer
- C-MOS Technology

■PACKAGE OUTLINE



NJU6365XC-X

■PAD LOCATION

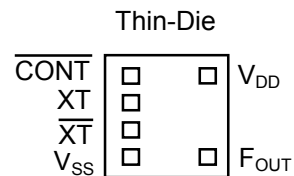

■LINE-UP TABLE

Type No.	F _{OUT}	Internal Connect	Cg/Cd	
NJU6364	A	f_0	Connected A Line	8/9pF
	B	$f_0/2$	Connected B Line	8/9pF
	C	$f_0/4$	Connected C Line	8/9pF
	D	$f_0/8$	Connected D Line	8/9pF
	E	$f_0/16$	Connected E Line	8/9pF
	F	$f_0/32$	Connected F Line	8/9pF

■COORDINATES

No	Pad Name	X	Y
1	CONT	-178	231
2	XT	-178	77
3	XT	-178	-77
4	V _{SS}	-178	-231
5	F _{OUT}	206	-231
8	V _{DD}	206	231

Starting Point: Chip Center Unit[um]
 Chip Size: 0.7x0.75mm
 Thin-Die Thickness(C-D): 200±20um
 Thin-Die Thickness(C-L): 140±10um
 Wafer Thickness(W-H): 200±20um
 Wafer Thickness(W-L): 140±10um
 Pad Size: 90x90um
 Die Substrate: V_{DD} Level

■BLOCK DIAGRAM

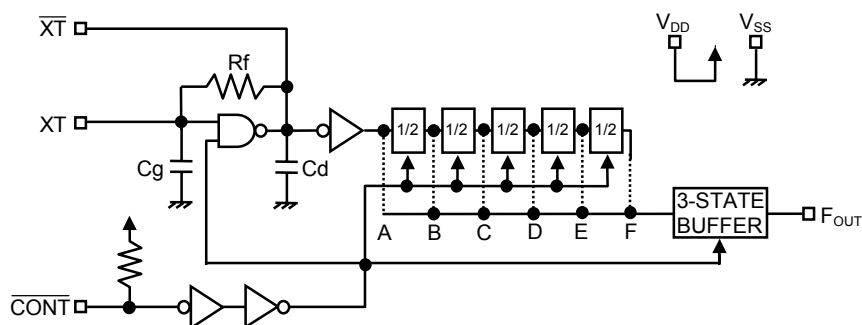

■ TERMINAL DESCRIPTION

SYMBOL	FUNCTION
CONT	Oscillation and 3-state Output Buffer Control
	CONT F _{OUT}
	H or OPEN Output either one frequency selected of f ₀ , f ₀ /2, f ₀ /4, f ₀ /8, f ₀ /16 and f ₀ /32 Note1)
	L Oscillation Stop and High impedance Output
XT XT	Quartz Crystal Connecting Terminals
V _{SS}	V _{SS} =0V
F _{OUT}	Frequency Output
V _{DD}	V _{DD} =2.5V/3.3V

Note1) Refer to the line-up table.

■ ABSOLUTE MAXIMUM RATINGS

(Ta=25°C)

PARAMETER	SYMBOL	RATING	UNIT
Supply Voltage	V _{DD}	-0.5 to +7.0	V
Input Voltage	V _{IN}	V _{SS} -0.5 to V _{DD} +0.5	V
Output Voltage	V _O	-0.5 to V _{DD} +0.5	V
Input Current	I _{IN}	±10	mA
Output Current	I _O	±25	mA
Operating Temperature Range	Topr	-40 to +85	°C
Storage Temperature Range	Tstg	-55 to +125	°C

Note2) If the supply voltage(V_{DD}) is less than 7.0V, the input voltage must not over the V_{DD} level though 7.0V is limit specified.

Note3) Decoupling capacitor should be connected between V_{DD} and V_{SS} due to the stabilized operation for the circuit.

■ ELECTRICAL CHARACTERISTICS

(Ta=25°C)

PARAMETER	SYMBOL	CONDITIONS	MIN	TYP	MAX	UNIT
Operating Voltage	V _{DD}		1.8		3.6	V

(V_{DD}=2.5V, Ta=25°C)

PARAMETER	SYMBOL	CONDITIONS	MIN	TYP	MAX	UNIT
Operating Current	I _{DD}	A version, fosc=16MHz, C _L =5pF			1.0	mA
		B version, fosc=16MHz, C _L =5pF			0.8	
		C version, fosc=16MHz, C _L =5pF			0.5	
		D version, fosc=16MHz, C _L =5pF			0.5	
		E version, fosc=16MHz, C _L =5pF			0.5	
		F version, fosc=16MHz, C _L =5pF			0.5	
Oscillation Stopping Current	I _{STB}	CONT=V _{SS} , No load			1	uA
Stand-by Current	I _{st}	CONT=XT=V _{SS} , No load Note4)			1	uA
Input Voltage	V _{IH}		1.75		2.5	V
	V _{IL}		0		0.75	V
Output Current	I _{OH}	V _{OH} =2.25V	1.2			mA
	I _{OL}	V _{OL} =0.25V	1.2			mA
Input Current	I _{IN}	CONT=0.8V _{DD}		3.6	5.5	uA
		CONT=0.2V _{DD}		0.3	0.5	uA
3-state Off Leakage Current	I _{OZ}	CONT=V _{SS} , F _{OUT} = V _{DD} or V _{SS}			±0.1	uA
Feedback Resistance	R _f			255		kΩ
Internal Capacitor	C _g /C _d	fosc=16MHz		8/9		pF
Maximum Oscillation Frequency	F _{MAX}		32			MHz
Output Signal Symmetry	SYM	C _L =5pF, @V _{DD} /2	45	50	55	%
Output Signal Rise Time	t _r	C _L =5pF, 10% to 90%		4	8	ns
Output Signal Fall Time	t _f	C _L =5pF, 90% to 10%		4	8	ns
Output Disable time	t _{PLZ}	C _L =5pF, R _{UP} =10kΩ			200	ns
Output Enable Time	t _{PZL}	C _L =5pF, R _{UP} =10kΩ			200	ns

Note4) Excluding input current on CONT Terminal.

(V_{DD}=3.3V, Ta=25°C)

PARAMETER	SYMBOL	CONDITIONS	MIN	TYP	MAX	UNIT
Operating Current	I _{DD}	A version, fosc=16MHz, C _L =5pF			1.5	mA
		B version, fosc=16MHz, C _L =5pF			1.2	
		C version, fosc=16MHz, C _L =5pF			1.0	
		D version, fosc=16MHz, C _L =5pF			1.0	
		E version, fosc=16MHz, C _L =5pF			1.0	
		F version, fosc=16MHz, C _L =5pF			1.0	
Oscillation Stopping Current	I _{STB}	CONT=V _{SS} , No load			1	uA
Stand-by Current	I _{st}	CONT=XT=V _{SS} , No load Note4)			1	uA
Input Voltage	V _{IH}		2.31		3.3	V
	V _{IL}		0		0.99	V
Output Current	I _{OH}	V _{OH} =2.97V	1.5			mA
	I _{OL}	V _{OL} =0.33V	1.5			mA
Input Current	I _{IN}	CONT=0.8V _{DD}		6.5	10	uA
		CONT=0.2V _{DD}		0.5	1	uA
3-state Off Leakage Current	I _{OZ}	CONT=V _{SS} , F _{OUT} = V _{DD} or V _{SS}			±0.1	uA
Feedback Resistance	R _f			255		kΩ
Internal Capacitor	C _g /C _d	fosc=16MHz		8/9		pF
Maximum Oscillation Frequency	F _{MAX}		32			MHz
Output Signal Symmetry	SYM	C _L =5pF, @V _{DD} /2	45	50	55	%
Output Signal Rise Time	t _r	C _L =5pF, 10% to 90%		3	6	ns
Output Signal Fall Time	t _f	C _L =5pF, 90% to 10%		3	6	ns
Output Disable time	t _{PLZ}	C _L =5pF, R _{UP} =10kΩ			150	ns
Output Enable Time	t _{PZL}	C _L =5pF, R _{UP} =10kΩ			150	ns

Note4) Excluding input current on CONT Terminal.

MEASUREMENT CIRCUITS

(1) Output Signal Symmetry ($C_L=5\text{pF}$)

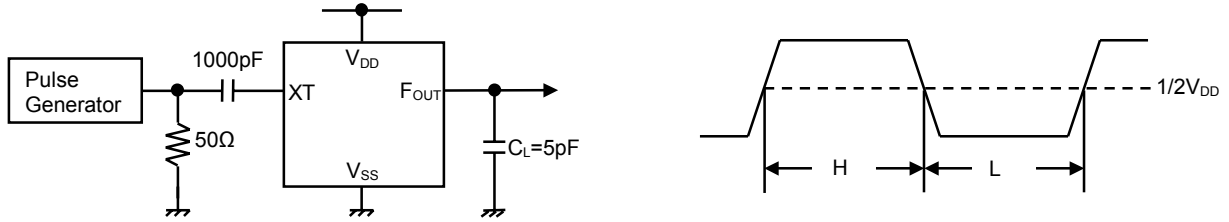

(2) Output Signal Rise/Fall Time ($C_L=5\text{pF}$)

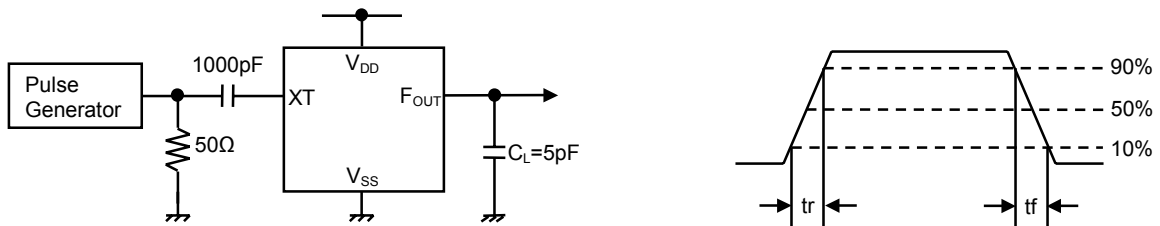

(3) Output Disable/Enable Time ($C_L=5\text{pF}, R_{UP}=10\text{k}\Omega$)

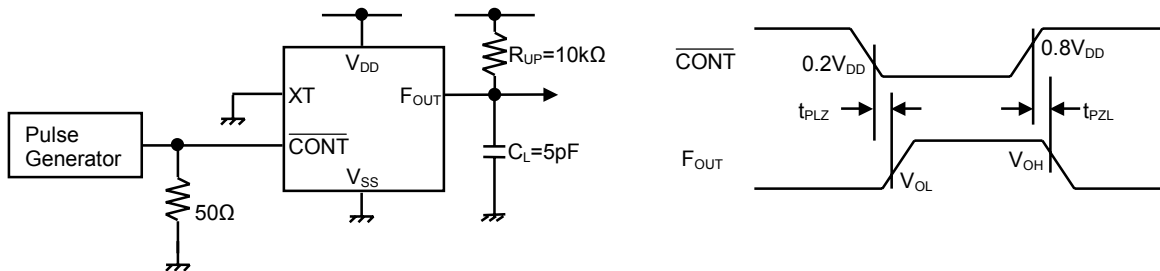

■ FREQUENCY STABILITY CHARACTERISTICS EXAMPLE

fcenter=16MHz, Vdd=2.5V±10%

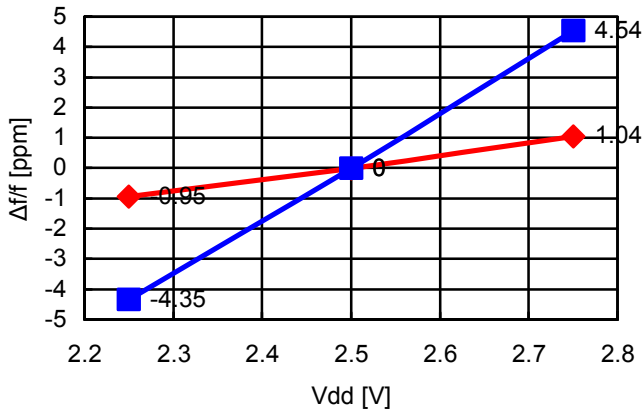

◆ NJU6365 ■ Previous

fcenter=16MHz, Vdd=3.3V±10%

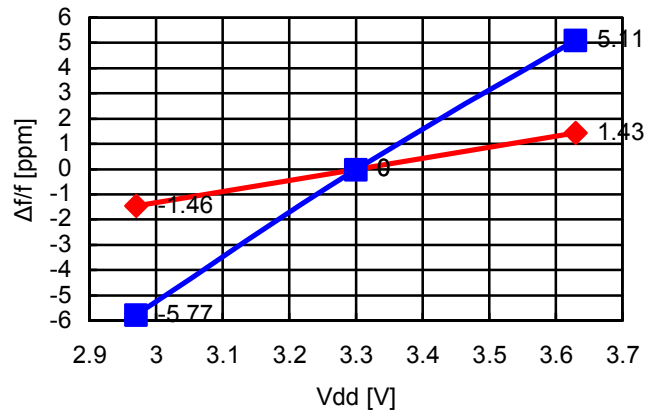

◆ NJU6365 ■ Previous

fcenter=32MHz, Vdd=2.5V±10%

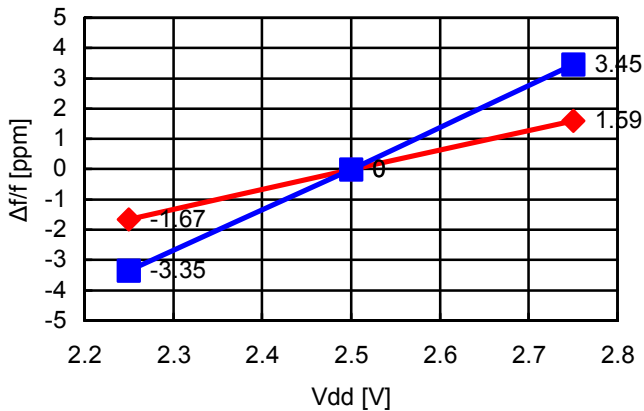

◆ NJU6365 ■ Previous

fcenter=32MHz, Vdd=3.3V±10%

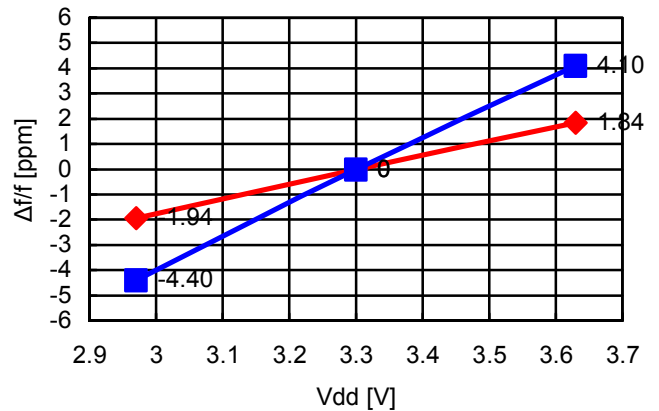

◆ NJU6365 ■ Previous

[CAUTION]
 The specifications on this data book are only given for information, without any guarantee as regards either mistakes or omissions. The application circuits in this data book are described only to show representative usages of the product and not intended for the guarantee or permission of any right including the industrial rights.