

S-band Magnetron

■ GENERAL DESCRIPTION

M1603 is a mechanical tuned pulsed type S-band magnetron intended primarily for linear accelerator. It is water cooled and has circle waveguide output type.

It is designed to operate in the frequency range of 2.993 to 3.002 GHz with a peak output power of 1.5 MW.

A magnet must be installed for operation this magnetron.



■ GENERAL CHARACTERISTICS

ELECTRICAL

PARAMETERS		
Heater voltage	(note 1)	8.5V
Heater current	(note 2)	9.0A
Minimum pre-heat time		180sec

MECHANICAL

PARAMETERS		
Overall Dimensions		See outline
Net weight		8 kg approximately
Tuner revolutions to cover frequency range (note 3)		4.75
Mounting position	(note 4)	Any
Cooling	(note 5)	Water
Output coupling		Waveguide transition NJC1301E or equivalent
Magnet	(note 6 and 7)	Excluded magnet in the package

■ ABSOLUTE MAXIMUM RATINGS

These ratings cannot necessarily be used simultaneously and no individual ratings should be exceeded.

PARAMETERS		Min.	Max.	Units
Magnetic field	(note 6 and 8)	126.0 1260	130.0 1300	mT gauss
Heater voltage	(note 1)	8.0	9.0	V
Anode voltage (peak)		-	38	kV
Anode current (peak)		60	90	A
Input power (mean)	(note 11)	-	3.2	kW
Duty cycle		-	0.0015	-
Pulse duration		-	5.0	μs
Frequency stability in pulse		-	0.2	MHz
Rate of rise of voltage pulse	(note 9)	80	110	kV/μs

PARAMETERS	Min.	Max.	Units
Outlet water temperature	-	50	°C
VSWR at the output coupler	-	1.5 : 1	-
Pressurizing of waveguide (note10)	-	0.3	MPa

■ TEST CONDITIONS AND LIMITS

The magnetron is tested to comply with the following electrical specification.

Test conditions		Units
Magnetic field (note 6 and 8)	128.0 ±2.0 1280 ±20	mT gauss
Heater voltage (operating)	0	V
Anode current (peak)	80	A
Duty cycle (note 11)	0.001	-
Pulse duration	4.5	µs
VSWR at the output coupler	1.05:1	-
Minimum rate of rise of voltage pulse (note 9)	90	kV/µs

Limits	Min.	Max.	Units
Anode voltage (peak)	33.5	37.0	kV
Output power (peak) (note 12)	1.5	-	MW
Frequency (note 13 and 14)			
Lower end of tuning range *	-	2993	MHz
Upper end of tuning range *	3002	-	MHz
R.F. bandwidth (t_p : Pulse duration)	-	2.5/ t_p	MHz
Frequency pulling (VSWR not less than 1.5 : 1)	-	7.0	MHz
Stability (note 15)	-	0.5	%
Heater current (note 2)	8	10	A

*: Inlet water at 40 degrees centigrade

■ LIFE TEST

End of life performance (under test conditions)

The magnetron is deemed to have reached the end of life when it fails to satisfy the following:

PARAMETERS	
Anode voltage (peak)	31 kV min.
Output power (peak)	1.3 MW min.
RF bandwidth (t_p : Pulse duration)	3.5/ t_p MHz max.

PARAMETERS	
Frequency	
Lower end of tuning range *	2993 MHz max.
Upper end of tuning range *	3002 MHz min.
Stability (note 15)	1% max.

*: Inlet water at 40 degrees centigrade

Notes

1. Heater voltage must be reduced within 5 seconds after the application of high voltage according to the schedule shown on page 5.
The magnetron heater must be protected against arcing by the use of a minimum capacitance of 4000 pF shunted across the heater directly at the input terminals; in some cases a capacitance as high as 2 μ F may be necessary depending on the equipment design.
2. Measured with heater voltage of 8.5 V and no anode input power, the heater current limits are 8.0A minimum, 10.0 A maximum.
3. The tuner mechanism is driven by means of three tapped holes in the tuner knob (see outline drawing) via a flexible drive. The torque required is 0.07 Nm minimum; the torque applied must not exceed 0.5 Nm.
4. To minimize frequency deviation when the magnetron is rotated about a horizontal axis, this axis should be parallel to the axis of the tuner.
5. M1603 is water cooled and has an integral water jacket.
The recommended water quality is pure grade.
The recommended water flow is 5 liters per minute or more; a pressure of approximately 0.125 MPa will be necessary to give this rate of flow.
The output water temperature must not exceed 50 degrees centigrade.
6. The magnetron is designed for use with a separate permanent magnet or electromagnet. The north seeking pole of the magnet must be adjacent to the cathode terminal, marked C. The position of the magnet must be adjusted so that the axis of the field is in line with the axis of the anode and is at right angles to the H plane of the system waveguide. And the stability tests are measured with permanent magnet type NJZ1283 or electromagnet type NJZ1285.
7. The M1603 can be used at lower power levels by reducing both the magnetic field (which controls the peak voltage) and the peak current (see graph shown on page 6); this is necessary for maintaining a good RF spectrum and constant impedance.
8. Using a small Hall effect probe, the magnetic field measured at each pole face of the magnet must be within the following limits:
(1) At the center of the pole face and 38 mm from the surface, the field must be 128.0 ± 2.0 mT (1280 ± 20 gauss).
(2) At four or more points equi-spaced on a circle of 33 mm diameter concentric with the pole face and 6.35 mm from its surface, including a point nearest the back limb of the magnet, the field must be as follows. At all points the field must be between 8.0 and 20 mT (80 and 200 gauss) greater than the field measured at the center of the pole face; the variation between the point must not exceed 10 mT (100 gauss).
9. Defined as steepest tangent to leading edge of voltage pulse above 80% amplitude. Any capacitance in viewing system must not exceed 6.0pF
10. At the maximum pressure of 0.3 MPa gauge the maximum leakage will be such that with an enclosed volume of 1 liter the pressure will not drop by more than 70 kPa in 7 days.

11. The various parameters are related by the following formula:

$$P_i = i_b \times e_{p_v} \times D_u$$

where	P _i : mean input power in W
	i _b : peak anode current in A
	e _{p_v} : peak anode voltage in V
	D _u : duty cycle

12. The maximum variation of mean output power when the magnetron is rotated through 360° around any axis of the magnetron will not be greater than 4%.
13. The maximum variation of frequency when the magnetron is rotated through 360° around any axis of the magnetron will not be greater than 0.7 MHz.
14. The frequency of the magnetron will vary after the application of anode voltage. Typically the frequency will be 0.5MHz high 20 seconds after switching on high voltage and 0.1 MHz high 5 minutes after switching on. And then, the inlet water temperature is 40 degrees centigrade.
15. With the tube operating into a VSWR of 1.15:1 phased to give maximum instability. Pulses are defined as missing when the RF energy level is less than 70% of the normal energy level in a 0.5% frequency range. Missing pulses are expressed as a percentage of the number of input pulses applied during the period of observation after a period of 10 minutes.



X-Ray Radiation

X-ray shield shall be placed around the magnetron at the magnetron installation. And also X-ray shield shall be placed especially covering over the input section of the magnetron, even though at the magnetron operation testing before installation into the system. Magnetrons is applied high voltage emit a significant intensity of X-rays.

These rays can constitute a health hazard unless adequate shielding for X-ray radiation is provided.

This is a characteristic of all magnetrons and the X-rays emitted correspond to a voltage much higher than that of the anode.

HEATER VOLTAGE REDUCTION SCHEDULE

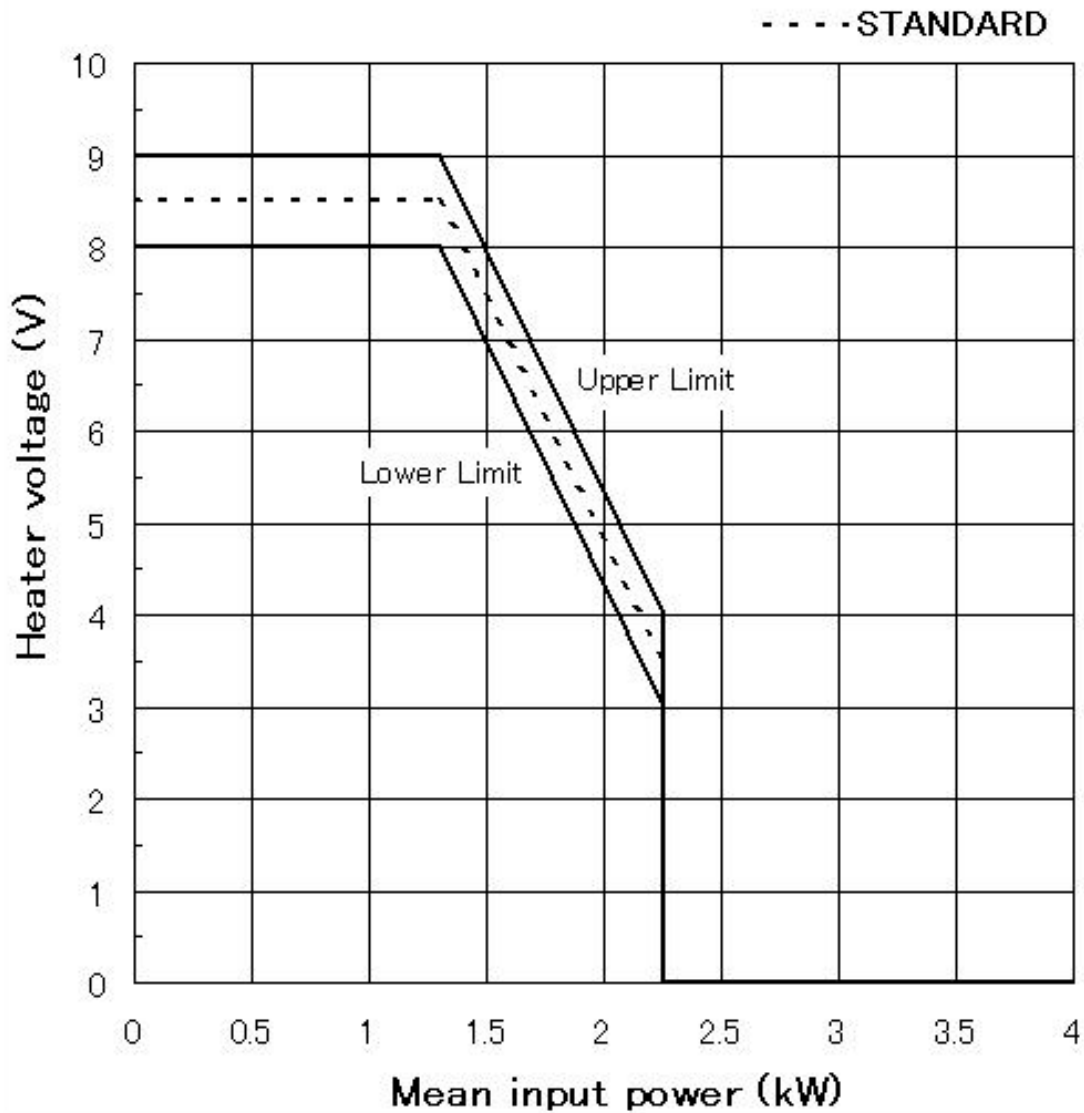

■ FREQUENCY ADJUSTMENT

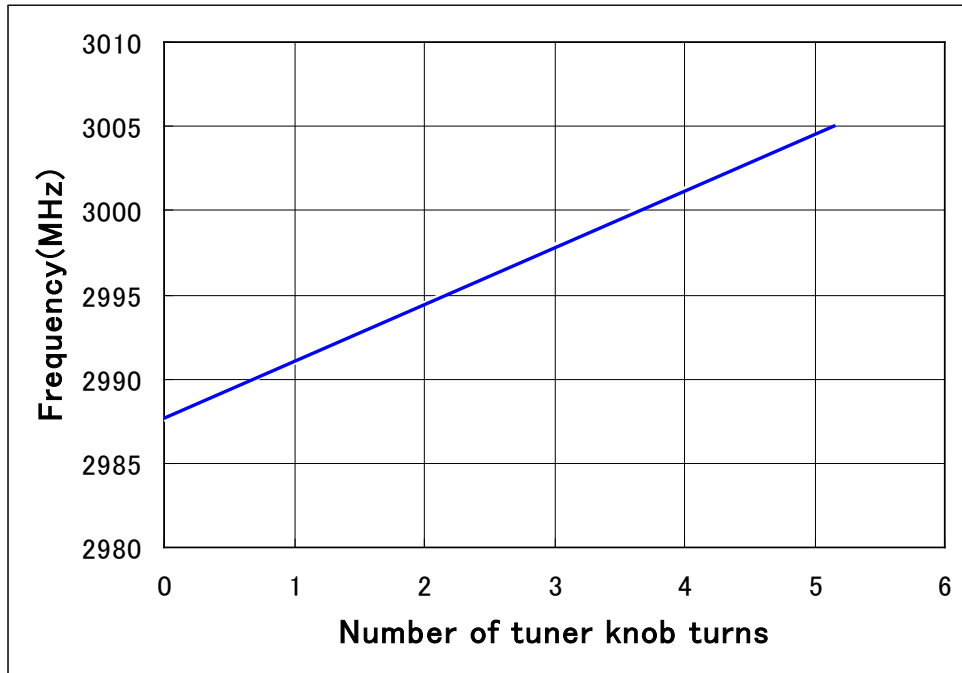

■ RECOMMENDED PARAMETER FOR VARIOUS POWER LEVELS

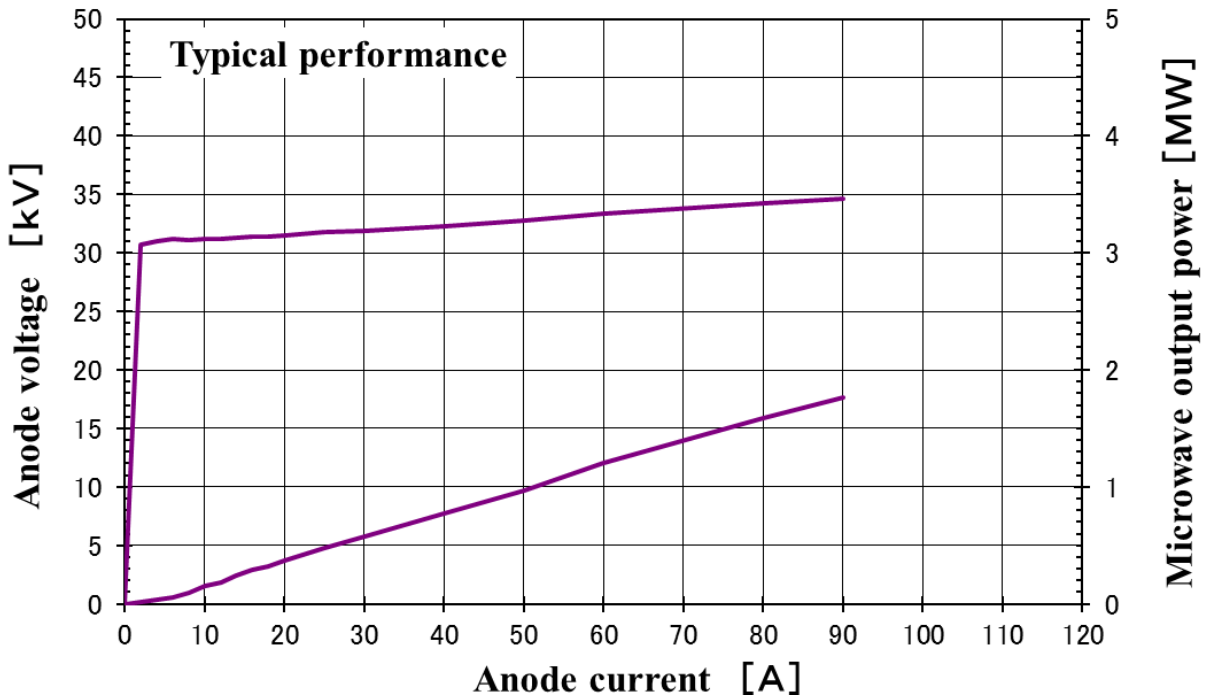

■ OUTLINE

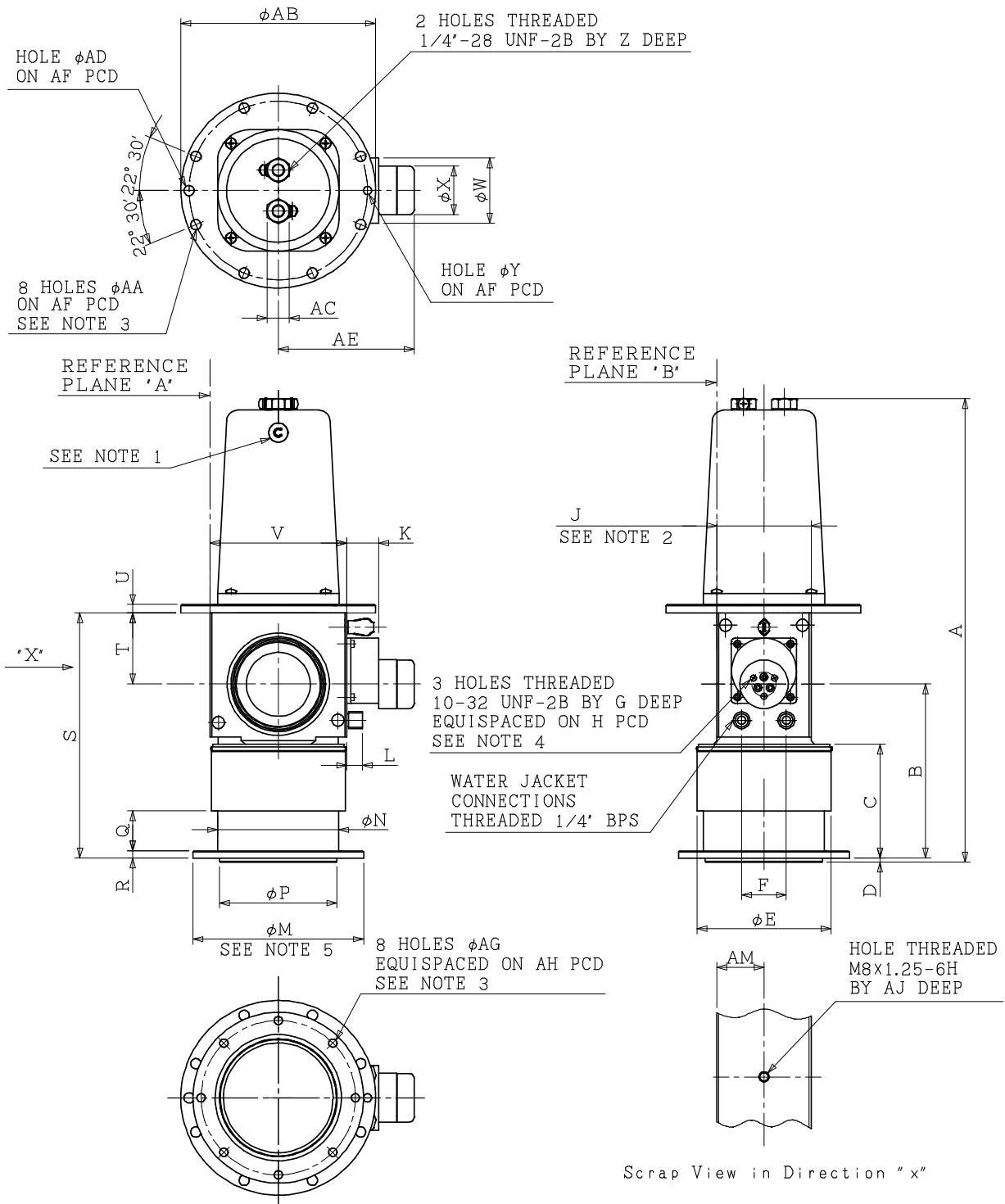

(All dimensions without limits are nominal)

Ref	Millimeters	Ref	Millimeters
A	362.4 ± 1.35	T	55.96 ± 0.16
B	135.89	U	6.35 ± 0.10
C	88.85	V	107.00
D	3.20	W	51 ± 0.10
E	104.90	X	38.10 ± 0.10
F	35.00	Y	6.40 ± 0.05
G	6.5 min.	Z	6.0 min.
H	19.00	AA	8.00
J	73.82 ± 0.20	AB	152.25
K	25.0	AC	17.00
L	12.50 ± 0.30	AD	8.00 ± 0.05
M	133.50	AE	106.4
N	94.85	AF	139.70
P	91.82	AG	6.40
Q	31.40	AH	120.65
R	5.55	AJ	15.0 min.
S	191.85	AM	36.91 ± 0.16

Outline Notes:

1. This surface is marked with letter 'C' to indicate the cathode terminal.
2. The magnetron will fit between magnet poles 76.45 mm diameter and 75.44 mm apart.
3. Positional tolerance of holes 0.15 mm diameter.
4. Positional tolerance of holes 0.05 mm diameter.
5. Positional tolerance of flange 1.5 mm diameter with respect to reference planes A and B.

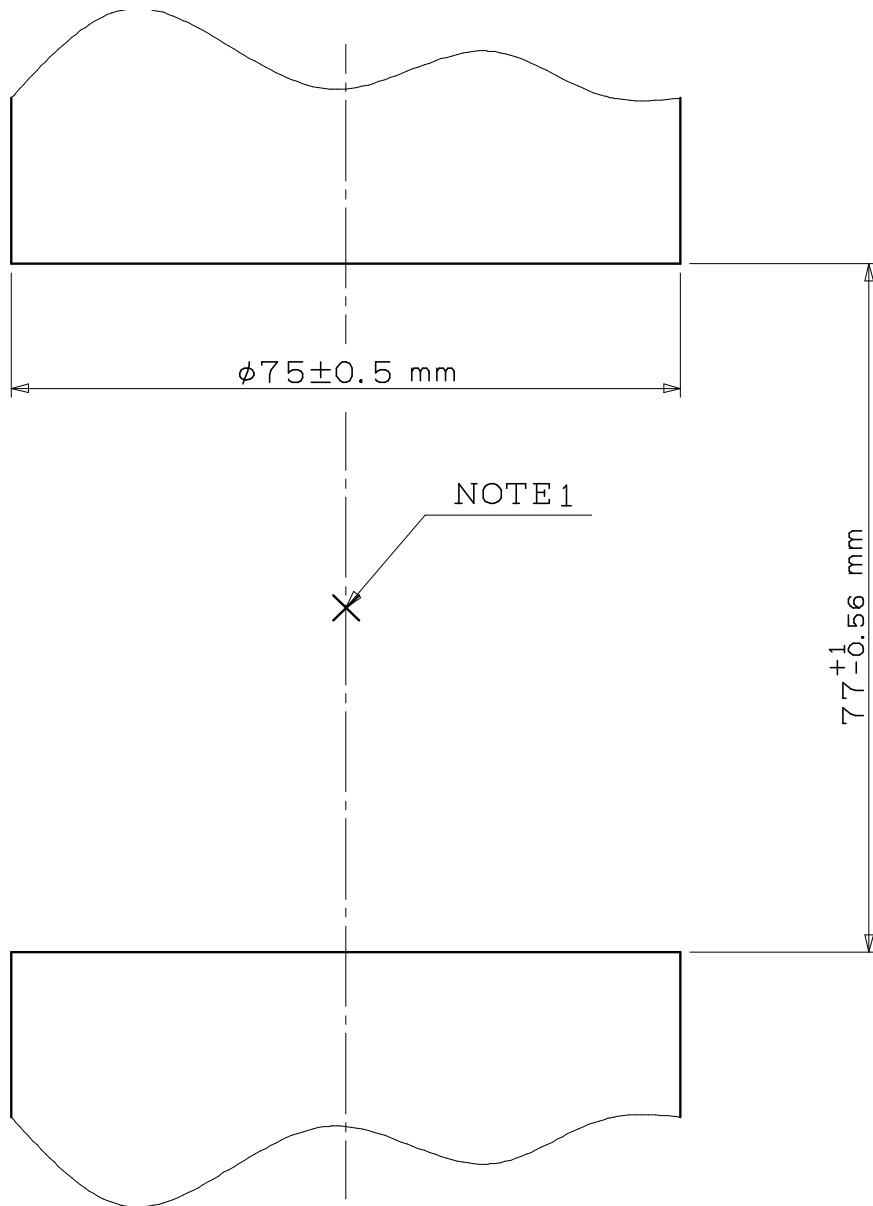
■ POLE PIECE

NOTE1: Magnetic field shall be $128.0 \pm 2.0 \text{ mT}$ at this point.

TRANSITION: NJC1301E

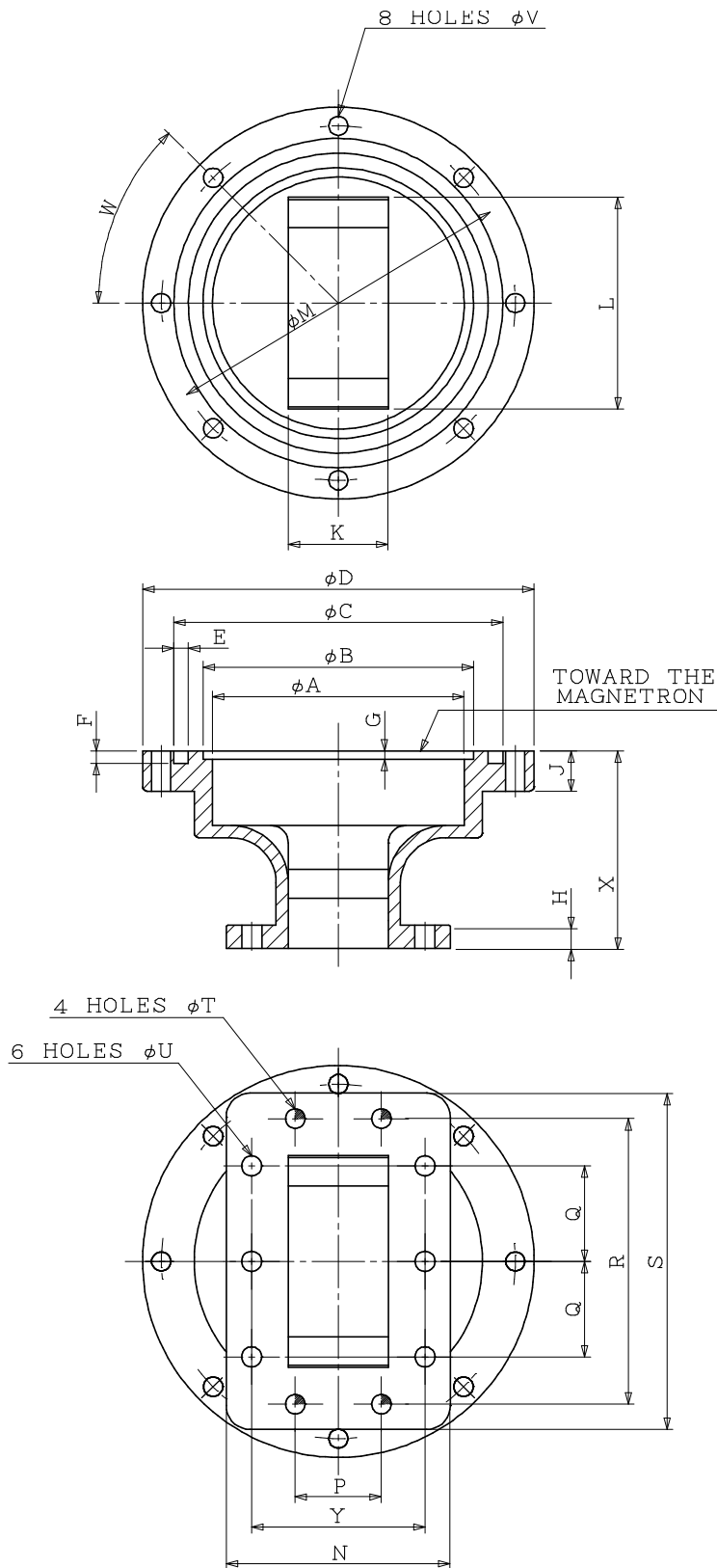

Ref	Millimeters
A	85.8
B	92.2 $^{+0.2}$
C	112.1 ± 0.1
D	133.4 ± 0.2
E	5 ± 0.1
F	4.1 $^{+0.15}_{-0.1}$
G	2.85 $^{0}_{-0.07}$
H	8 ± 0.3
J	13.6 ± 0.2
K	34.1 ± 0.13
L	72.2 ± 0.13
M	120.7 ± 0.1
N	76.4
P	29.36 ± 0.05
Q	32.5 ± 0.13
R	97.2 ± 0.08
S	114.5
T	6.65 ± 0.05
U	6.85 ± 0.08
V	6.5 ± 0.13
W	45°
X	67.15 ± 0.13
Y	59.1 ± 0.15

(All dimensions without limits are nominal)

*Note: The contents of this sheet are subject to change without notice.