

2-CHANNEL ELECTRONIC VOLUME WITH INPUT SELECTOR AND TONE CONTROL

■ GENERAL DESCRIPTION

The NJW1194 is a 2-channel electronic volume with 4-in 1-out stereo audio selector and Tone Control. The NJW1194 performs low noise and low distortion characteristics with resistance ladder circuit.

All of functions are controlled via three-wired serial bus. Selectable 4-Chip address is available for using four chips on same serial bus line.

It's suitable for two-channel stereo system and or multi-channel audio system.

■ PACKAGE OUTLINE



NJW1194V

■ FEATURES

- Operating Voltage ±4.5 to ±7.5V
- 3-Wired Serial Control Chip Address Select Function
- Low output noise -117dBVtyp.
- Low THD 0.0015%typ. (Vin=2Vrms, VOL=0dB)
- Input Selector(X4)
- Volume +31.5 to -95.0dB / 0.5dBstep, MUTE
- Tone Control 0to ±10dB/1dBstep
- Channel Separation -120dBtyp.
- Zero Cross Detection
- Bi-CMOS Technology
- Package Outline SSOP32

■ BLOCK DIAGRAM

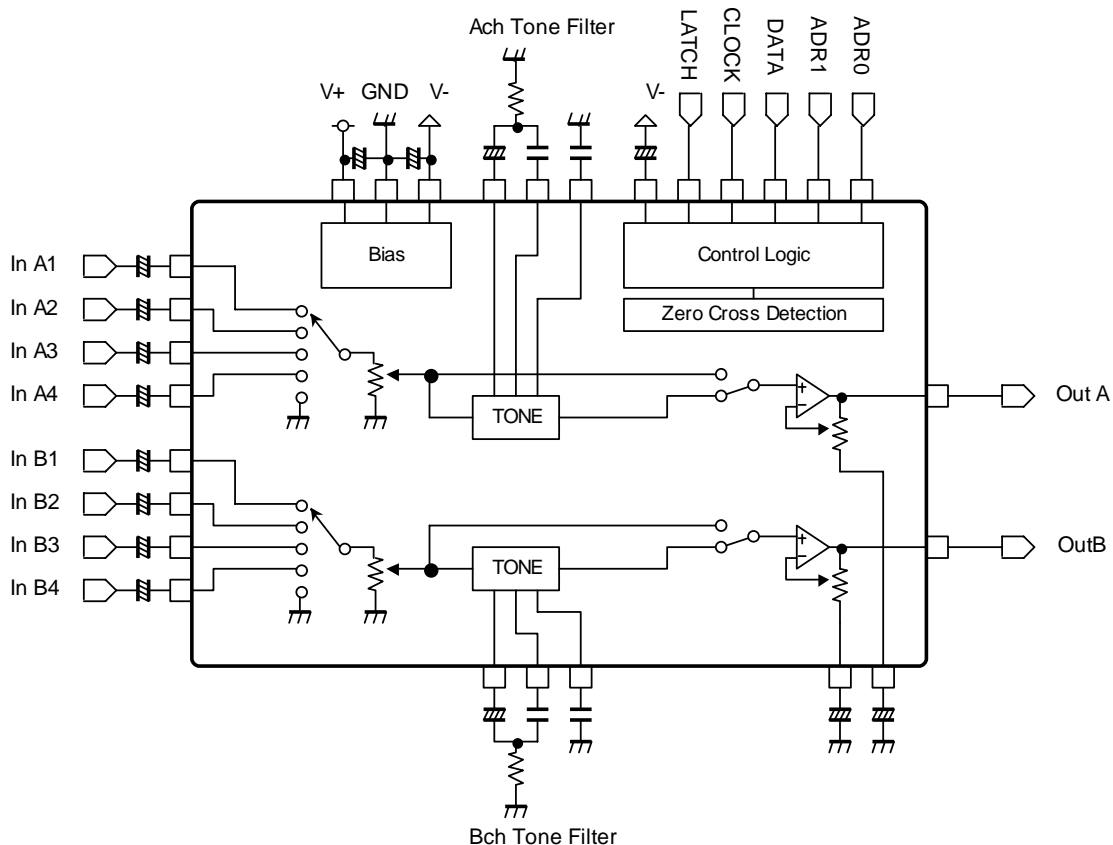

NJW1194

■ PIN FUNCTION

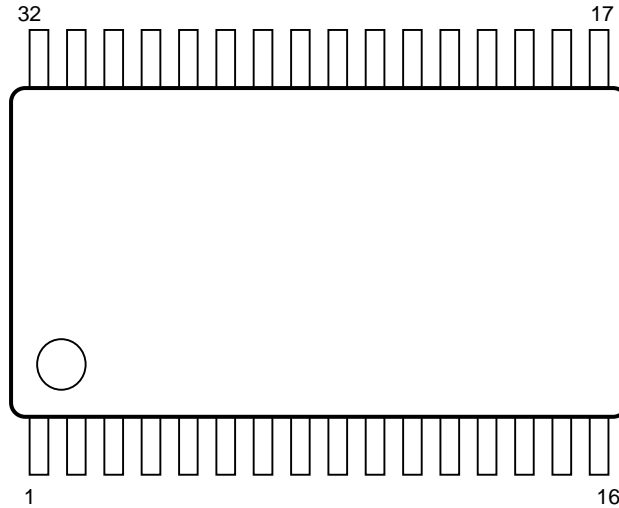

No.	SYMBOL	FUNCTION	No.	SYMBOL	FUNCTION
1	InA1	Ach Input 1	17	Tone_Ba2b	Bch Bass Filter Terminal 2
2	InA2	Ach Input 2	18	Tone_Ba1b	Bch Bass Filter Terminal 1
3	InA3	Ach Input 3	19	Tone_Tr1b	Bch Treble Filter Terminal 1
4	InA4	Ach Input 4	20	GND	Ground
5	GND	Ground	21	V -	Power Supply (-)
6	DCCAP_A	Switching noise rejection capacitor (Ach)	22	V+	Power Supply (+)
7	GND	Ground	23	ADR0	Chip address setting terminal 0
8	OutA	Ach Output	24	ADR1	Chip address setting terminal 1
9	VDDOUT	Internal Digital Power Supply output	25	OutB	Bch Output
10	DATA	Control data signal input	26	GND	Ground
11	CLOCK	Clock signal input	27	DCCAP_B	Switching noise rejection capacitor (Bch)
12	LATCH	Latch signal input	28	GND	Ground
13	GND	Ground	29	InB4	Bch Input 4
14	Tone_Tr1a	Ach Treble Filter Terminal 1	30	InB3	Bch Input 3
15	Tone_Ba1a	Ach Bass Filter Terminal 1	31	InB2	Bch Input 2
16	Tone_Ba2a	Ach Bass Filter Terminal 2	32	InB1	Bch Input 1

■ ABSOLUTE MAXIMUM RATING (Ta=25°C)

PARAMETER	SYMBOL	RATING	UNIT
Power Supply Voltage	V ₊ /V ₋	+8/-8	V
Maximum Input Voltage	V _{IM}	V ₊ /V ₋	V
Power Dissipation	P _D	1000 <small>NOTE: EIA/JEDEC STANDARD Test board (76.2x114.3x1.6mm, 2layer, FR-4) mounting</small>	mW
Operating Temperature Range	Topr	-40 ~ +85	°C
Storage Temperature Range	Tstg	-40 ~ +125	°C

■ ELECTRICAL CHARACTERISTICS (Ta=25°C, V⁺/V⁻=±7V, RL=47kΩ, Volume=0dB, TONE=OFF, In:input, Out:output)

PARAMETER	SYMBOL	TEST CONDITION	MIN.	TYP.	MAX.	UNIT
◆ Power Supply						
Operating Voltage	V ₊ /V ₋		±4.5	±7.0	±7.5	V
Supply Current 1	I _{CC}	No signal	-	12	17	mA
Supply Current 2	I _{EE}	No signal	-	12	17	mA
◆ Input/Output Characteristics (Output)						
Maximum Output Voltage	V _{OM}	f=1kHz, THD=1% VOL=0dB	3.6	4.2	-	Vrms
Voltage Gain1	G _{V1}	V _{IN} =2Vrms, f=1kHz VOL=0dB	-0.5	0	0.5	dB
Voltage Gain2	G _{V2}	V _{IN} =100mVrms, f=1kHz VOL=+15dB	+14	+15	+16	dB
Voltage Gain Error1	ΔG _{V1}	V _{IN} =2Vrms, f=1kHz VOL=0dB	-0.5	0	0.5	dB
Voltage Gain Error2	ΔG _{V2}	f=1kHz, V _{IN} =2Vrms VOL=-60dB	-1.0	0	1.0	dB
Maximum Attenuation	A _{TT}	f=1kHz, V _{IN} =2Vrms VOL=-95dB, A-weight	-	-95	-	dB
Mute Level	Mute	f=1kHz, V _{IN} =2Vrms VOL=Mute, A-weight	-	-120	-	dB
Cross Talk 1	CT1	f=1kHz, V _{IN} =2Vrms, A-weight VOL=0dB, Rg=0Ω	-	-120	-	dB
Cross Talk 2	CT2	f=20kHz, V _{IN} =2Vrms VOL=0dB, Rg=0Ω	-	-100	-	dB
Channel Separation 1	CS1	f=1kHz, V _{IN} =2Vrms, A-weight VOL=0dB, Rg=0Ω	-	-120	-90	dB
Channel Separation 2	CS2	f=20kHz, V _{IN} =2Vrms VOL=0dB, Rg=0Ω	-	-100	-	dB
Channel Separation 3	CS3	f=1kHz, V _{IN} =2Vrms, A-weight VOL=0dB, Rg=0Ω TONE=ON (Bass=Treble=0dB)	-	-110	-90	dB
Channel Separation 4	CS4	f=20kHz, V _{IN} =2Vrms VOL=0dB, Rg=0Ω TONE=ON (Bass=Treble=0dB)	-	-90	-	dB
Input Impedance	R _{IN}	Select Channel Input Terminal	15	20	-	kΩ

■ **ELECTRICAL CHARACTERISTICS** (Ta=25°C, V⁺/V⁻=±7V, RL=47kΩ, Volume=0dB, TONE=OFF, In:input,Out:output)

PARAMETER	SYMBOL	TEST CONDITION	MIN.	TYP.	MAX.	UNIT
◆ Input/Output Characteristics (Output)						
Output Noise1	V _{NO1}	VOL=0dB, Rg=0Ω, A-weight, TONE=ON (Bass=Treble=0dB)	-	-113 (2.2μ)	-100 (10μ)	dBV (Vrms)
Output Noise2	V _{NO2}	VOL=0dB, Rg=0Ω, A-weight, TONE=OFF	-	-117 (1.41μ)	-	dBV (Vrms)
Total Harmonic Distortion 1	THD1	f=1kHz, V _{IN} =200mVrms, VOL=0dB, BW=400Hz-30kHz TONE=ON (Bass=Treble=0dB)	-	0.002	-	%
Total Harmonic Distortion 2	THD2	f=10kHz, V _{IN} =200mVrms, VOL=0dB, BW=400Hz-30kHz TONE=ON (Bass=Treble=0dB)	-	0.002	-	%
Total Harmonic Distortion 3	THD3	f=1kHz, V _{IN} =2Vrms, VOL=0dB, BW=400Hz-30kHz TONE=ON (Bass=Treble=0dB)	-	0.0015	-	%
Total Harmonic Distortion 4	THD4	f=10kHz, V _{IN} =2Vrms, VOL=0dB, BW=400Hz-30kHz TONE=ON (Bass=Treble=0dB)	-	0.005	-	%
Total Harmonic Distortion 5	THD5	f=1kHz, V _{IN} =200mVrms, VOL=+15dB, BW=400Hz-30kHz TONE=ON (Bass=Treble=0dB)	-	0.002	-	%
Total Harmonic Distortion 6	THD6	f=10kHz, V _{IN} =200mVrms, VOL=+15dB, BW=400Hz-30kHz TONE=ON (Bass=Treble=0dB)	-	0.002	-	%
Total Harmonic Distortion 7	THD7	f=1kHz, V _{IN} =2Vrms, VOL=-18dB, BW=400Hz-30kHz TONE=ON (Bass=Treble=0dB)	-	0.002	0.02	%
Total Harmonic Distortion 8	THD8	f=10kHz, V _{IN} =2Vrms, VOL=-18dB, BW=400Hz-30kHz TONE=ON (Bass=Treble=0dB)	-	0.002	-	%

■ ELECTRICAL CHARACTERISTICS (Ta=25°C, V⁺/V⁻=±7V, RL=47kΩ, Volume=0dB, TONE=OFF, In:input,Out:output)

PARAMETER	SYMBOL	TEST CONDITION	MIN.	TYP.	MAX.	UNIT
◆Tone Control Characteristics						
Treble Voltage Gain 1	G _{VTREB1}	V _{IN} =100mVrms, f=10kHz VOL=0dB, TONE=ON, Treble=0dB	-2.0	0	2.0	dB
Treble Voltage Gain 2	G _{VTREB2}	V _{IN} =100mVrms, f=10kHz VOL=0dB, TONE=ON, Treble=+10dB	8.0	10.0	12.0	dB
Treble Voltage Gain 3	G _{VTREB3}	V _{IN} =100mVrms, f=10kHz VOL=0dB, TONE=ON, Treble=-10dB	-12.0	-10.0	-8.0	dB
Bass Voltage Gain 1	G _{VBASS1}	V _{IN} =100mVrms, f=100Hz VOL=0dB, TONE=ON, Bass=0dB	-2.0	0	2.0	dB
Bass Voltage Gain 2	G _{VBASS2}	V _{IN} =100mVrms, f=100Hz VOL=0dB, TONE=ON, Bass=+10dB	8.0	10.0	12.0	dB
Bass Voltage Gain 3	G _{VBASS3}	V _{IN} =100mVrms, f=100Hz VOL=0dB, TONE=ON, Bass=-10dB	-12.0	-10.0	-8.0	dB
◆Logic Control Characteristics						
High Level Input Voltage	V _{IH}	DATA, CLOCK, LATCH, ADR0, ADR1	2.5	-	V ⁺	V
Low Level Input Voltage	V _{IL}	DATA, CLOCK, LATCH, ADR0, ADR1	0	-	1.5	V

■ TERMINAL DESCRIPTION

PIN NO.	SYMBOL	FUNCTION	EQUIVALENT CIRCUIT	TERMINAL DC VOLTAGE
1 2 3 4 32 31 30 29	InA1 InA2 InA3 InA4 InB1 InB2 InB3 InB4	Ach Input 1 Ach Input 2 Ach Input 3 Ach Input 4 Bch Input 1 Bch Input 2 Bch Input 3 Bch Input 4		0V
5 7 13 20 26 28	GND	Ground		0V
6 27	DCCAP_A DCCAP_B	Switching noise rejection capacitor (Ach) Switching noise rejection capacitor (Bch)		0V
8 25	OutA OutB	Ach Output Bch Output		0V
9	VDDOUT	Internal Digital Power Supply output		V-(sub) + 5V

■ TERMINAL DESCRIPTION

PIN NO.	SYMBOL	FUNCTION	EQUIVALENT CIRCUIT	TERMINAL DC VOLTAGE
10 11 12 23 24	DATA CLOCK LATCH ADR0 ADR1	Control data signal input Clock signal input Latch signal input Chip address setting terminal 0 Chip address setting terminal 1		-
14 19	Tone_Tr1a Tone_Tr1b	Ach Treble Filter Terminal 1 Bch Treble Filter Terminal 1		0V
15 18	Tone_Ba1a Tone_Ba1b	Ach Bass Filter Terminal 1 Bch Bass Filter Terminal 1		0V
16 17	Tone_Ba2a Tone_Ba2b	Ach Bass Filter Terminal 2 Bch Bass Filter Terminal 2		0V
22	V+	Power Supply (+)		V+

APPLICATION CIRCUIT

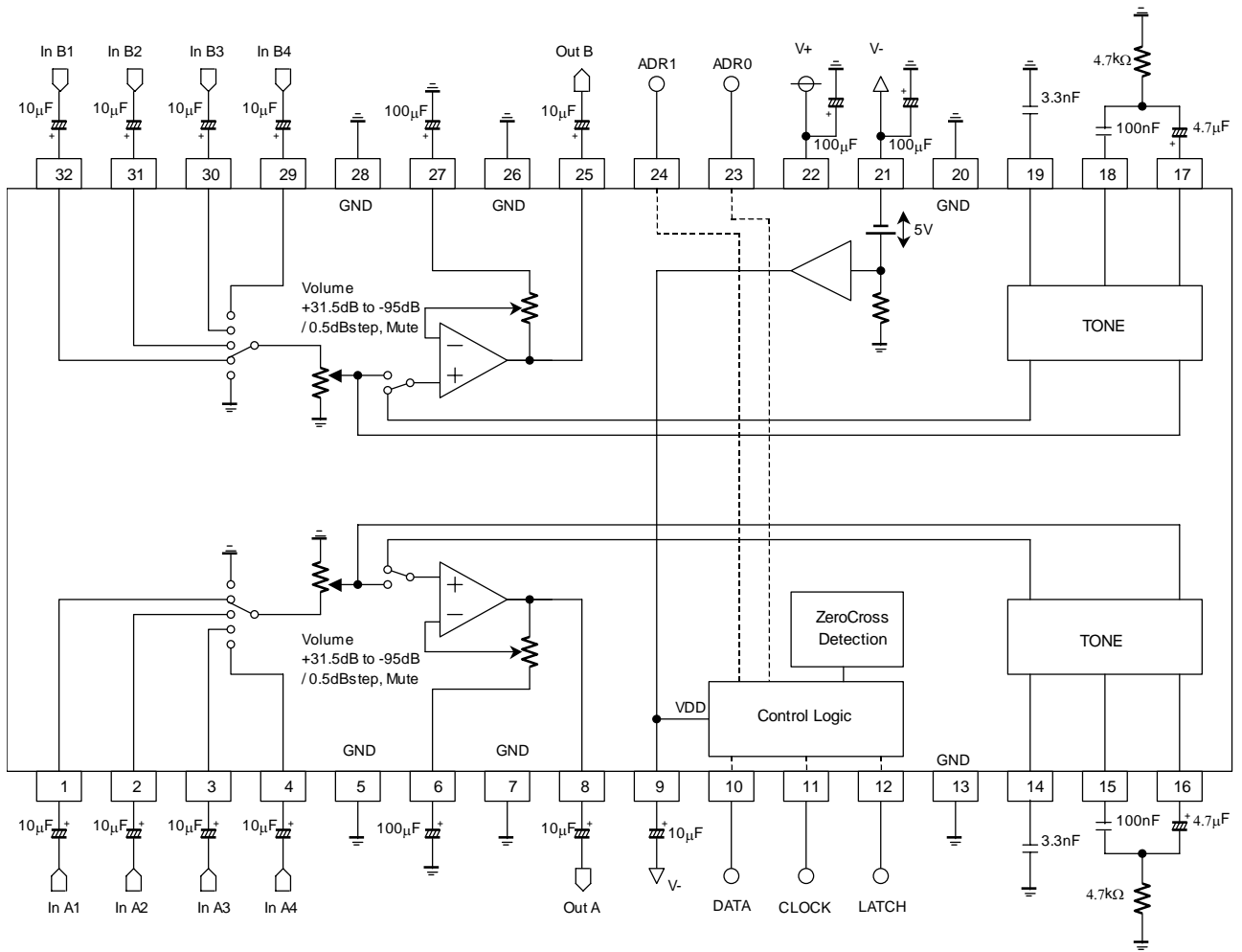

Note.) When switching TSW(Tone Control By-pass Switch), use MUTE on the set.

APPLICATION NOTE

(1) TONE Control Application suggestions

(a) Bass Control

(a-1) Boost

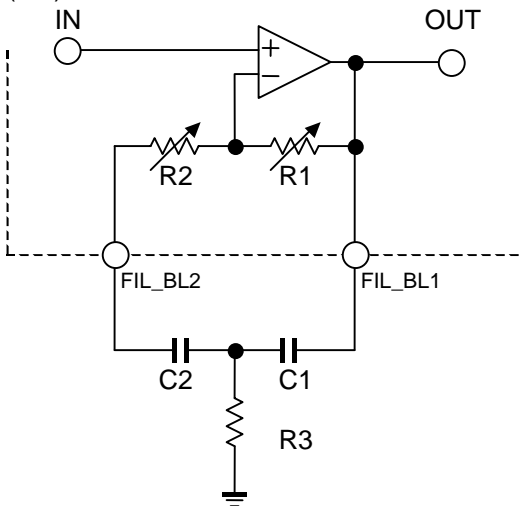

(a-2) Cut

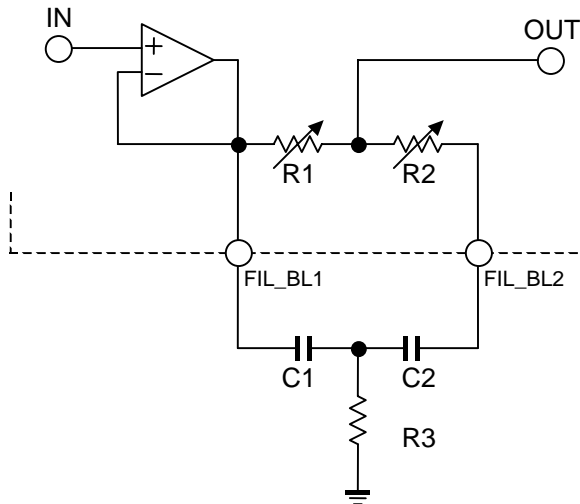

$$f_0 = \frac{1}{2\pi\sqrt{(R1+R2)\times R3\times C1\times C2}}$$

$$Q = \frac{\sqrt{(R1+R2)\times R3\times C1\times C2}}{R2\times C2 + R3\times (C1+C2)}$$

$$G_0 = \pm 20\text{Log} \frac{(R1+R2+R3)\times C2 + R3\times C1}{C2\times R2 + (C1+C2)\times R3}$$

Table.a-1 : Internal resistance in each Gain.

C1=100nF, C2=4.7uF, R3=4.7 kΩ

Gain	R1	R2
±10dB	32.5 kΩ	3.5 kΩ
±9dB	30.1 kΩ	5.9 kΩ
±8dB	27.65 kΩ	8.35 kΩ
±7dB	25.15 kΩ	10.85 kΩ
±6dB	22.45 kΩ	13.55 kΩ
±5dB	19.55 kΩ	16.45 kΩ
±4dB	16.4 kΩ	19.6 kΩ
±3dB	12.9 kΩ	23.1 kΩ
±2dB	9 kΩ	27 kΩ
±1dB	4.75 kΩ	31.25 kΩ

(b) Treble Control
 (b-1) Boost

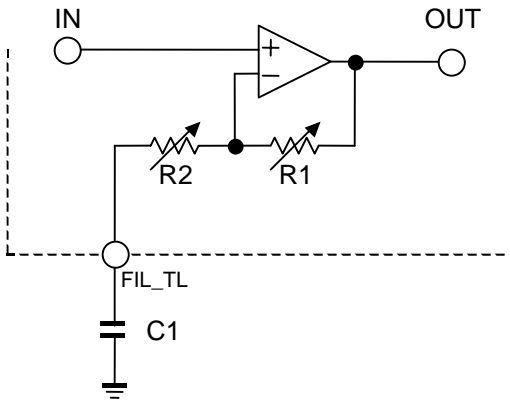

(b-2) Cut

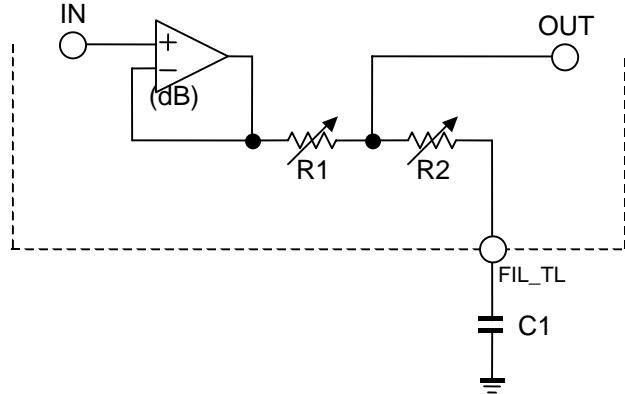

$$G_V = \pm 20 \text{Log} \left[1 + \frac{R1}{R2} \times \frac{1}{\sqrt{1 + (1/(\omega \times C1 \times R2))^2}} \right]$$

Table.b-1 : Internal resistance in each Gain.

C1=3.3nF

Gain	R1	R2
±10dB	21.7 kΩ	8.4 kΩ
±9dB	20.37 kΩ	9.73 kΩ
±8dB	18.92 kΩ	11.18 kΩ
±7dB	17.32 kΩ	12.78 kΩ
±6dB	15.56 kΩ	14.54 kΩ
±5dB	13.61 kΩ	16.49 kΩ
±4dB	11.46 kΩ	18.64 kΩ
±3dB	9.06 kΩ	21.04 kΩ
±2dB	6.36 kΩ	23.74 kΩ
±1dB	3.36 kΩ	26.74 kΩ

■ CONTROL DATA FORMAT

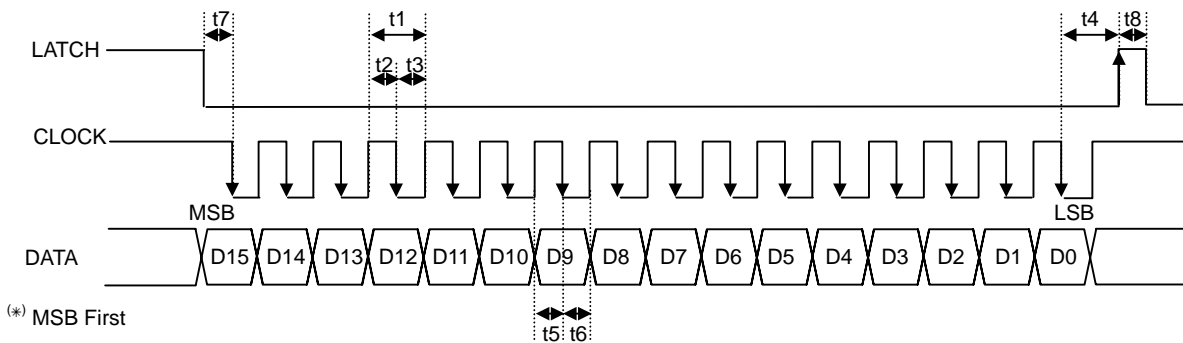

Note.) Set CLOCK in High to prevent incorrect operation during a standby period.

SYMBOL	PARAMETER	MIN	TYP	MAX	UNIT
t1	CLOCK Clock Width	4	-	-	μsec
t2	CLOCK Pulse Width (High)	2	-	-	μsec
t3	CLOCK Pulse Width (Low)	2	-	-	μsec
t4	LATCH Rise Hold Time	4	-	-	μsec
t5	DATA Setup Time	1.6	-	-	μsec
t6	DATA Hold Time	1.6	-	-	μsec
t7	CLOCK Setup Time	1.6	-	-	μsec
t8	LATCH High Pulse Width	1.6	-	-	μsec

■ CONTROL DATA

NJW1194 control data is constructed with 16bits.

MSB															LSB
D15	D14	D13	D12	D11	D10	D9	D8	D7	D6	D5	D4	D3	D2	D1	D0
Data								Select Address				Chip Address			
MSB															LSB
D15	D14	D13	D12	D11	D10	D9	D8	D7	D6	D5	D4	D3	D2	D1	D0
Volume Control 1								0	0	0	0	*	*	*	*
Volume Control 2								0	0	0	1	*	*	*	*
Don't Care				Input selector		Don't Care	Don't Care	0	0	1	0	*	*	*	*
TC/B	Treble control				TSW	Don't Care	Don't Care	0	0	1	1	*	*	*	*
BC/B	Bass control				Don't Care	Don't Care	Don't Care	0	1	0	0	*	*	*	*

* Chip address is set by chip address select terminal (ADR) status.

chip address select terminal		Chip Address			
ADR1	ADR0	D3	D2	D1	D0
Low	Low	0	0	0	0
Low	High	0	0	0	1
High	Low	0	0	1	0
High	High	0	0	1	1

■ INITIAL CONDITION

MSB															LSB
D15	D14	D13	D12	D11	D10	D9	D8	D7	D6	D5	D4	D3	D2	D1	D0
1	1	1	1	1	1	1	1	0	0	0	0	*	*	*	*
1	1	1	1	1	1	1	1	0	0	0	1	*	*	*	*
0	0	0	0	0	0	0	0	0	0	1	0	*	*	*	*
0	0	0	0	0	0	0	0	0	0	1	1	*	*	*	*
0	0	0	0	0	0	0	0	0	1	0	0	*	*	*	*

Note.) This product starts up by MUTE setting in power "ON". Use it after removing MUTE of each setting.

If any audio signal is inputted in input signal terminal before power "ON", it may cause initial condition abnormality.

In conditions of use such as the above, it prevents that abnormality by setting MUTE before power "OFF"

■ DEFINITION OF RESISTOR

◆Volume control1, Volume control2 +31.5dB to -95dB in 0.5dB/step. *Each volume is controlled independently.

D15	D14	D13	D12	D11	D10	D9	D8	D7	D6	D5	D4	D3	D2	D1	D0
Volume control 1								0	0	0	0	*	*	*	*
Volume control 2								0	0	0	1	*	*	*	*

< Volume Control Data >

Data								Setting
D15	D14	D13	D12	D11	D10	D9	D8	
0	0	0	0	0	0	0	0	Mute
0	0	0	0	0	0	0	1	+31.5dB
0	0	0	0	0	0	1	0	+31.0dB
0	0	0	0	0	0	1	1	+30.5dB
0	0	0	0	0	1	0	0	+30.0dB
0	0	0	0	0	1	0	1	+29.5dB
0	0	0	0	0	1	1	0	+29.0dB
0	0	0	0	0	1	1	1	+28.5dB
0	0	0	0	1	0	0	0	+28.0dB
0	0	0	0	1	0	0	1	+27.5dB
0	0	0	0	1	0	1	0	+27.0dB
0	0	0	0	1	0	1	1	+26.5dB
0	0	0	0	1	1	0	0	+26.0dB
0	0	0	0	1	1	0	1	+25.5dB
0	0	0	0	1	1	1	0	+25.0dB
0	0	0	0	1	1	1	1	+24.5dB
0	0	0	1	0	0	0	0	+24.0dB
0	0	0	1	0	0	0	1	+23.5dB
0	0	0	1	0	0	1	0	+23.0dB
0	0	0	1	0	0	1	1	+22.5dB
0	0	0	1	0	1	0	0	+22.0dB
0	0	0	1	0	1	0	1	+21.5dB
0	0	0	1	0	1	1	0	+21.0dB
0	0	0	1	0	1	1	1	+20.5dB
0	0	0	1	1	0	0	0	+20.0dB
0	0	0	1	1	0	0	1	+19.5dB
0	0	0	1	1	0	1	0	+19.0dB
0	0	0	1	1	0	1	1	+18.5dB
0	0	0	1	1	1	0	0	+18.0dB
0	0	0	1	1	1	0	1	+17.5dB
0	0	0	1	1	1	1	0	+17.0dB
0	0	0	1	1	1	1	1	+16.5dB
0	0	1	0	0	0	0	0	+16.0dB
0	0	1	0	0	0	0	1	+15.5dB
0	0	1	0	0	0	1	0	+15.0dB
0	0	1	0	0	0	1	1	+14.5dB
0	0	1	0	0	1	0	0	+14.0dB
0	0	1	0	0	1	0	1	+13.5dB
0	0	1	0	0	1	1	0	+13.0dB
0	0	1	0	0	1	1	1	+12.5dB
0	0	1	0	1	0	0	0	+12.0dB
0	0	1	0	1	0	0	1	+11.5dB
0	0	1	0	1	0	1	0	+11.0dB
0	0	1	0	1	0	1	1	+10.5dB
0	0	1	0	1	1	0	0	+10.0dB
0	0	1	0	1	1	0	1	+9.5dB
0	0	1	0	1	1	1	0	+9.0dB
0	0	1	0	1	1	1	1	+8.5dB
0	0	1	1	0	0	0	0	+8.0dB

< Volume Control Data >

DATA								Setting
D15	D14	D13	D12	D11	D10	D9	D8	
0	0	1	1	0	0	0	1	+7.5dB
0	0	1	1	0	0	1	0	+7.0dB
0	0	1	1	0	0	1	1	+6.5dB
0	0	1	1	0	1	0	0	+6.0dB
0	0	1	1	0	1	0	1	+5.5dB
0	0	1	1	0	1	1	0	+5.0dB
0	0	1	1	0	1	1	1	+4.5dB
0	0	1	1	1	0	0	0	+4.0dB
0	0	1	1	1	0	0	1	+3.5dB
0	0	1	1	1	0	1	0	+3.0dB
0	0	1	1	1	0	1	1	+2.5dB
0	0	1	1	1	1	0	0	+2.0dB
0	0	1	1	1	1	0	1	+1.5dB
0	0	1	1	1	1	1	0	+1.0dB
0	0	1	1	1	1	1	1	+0.5dB
0	1	0	0	0	0	0	0	0dB
0	1	0	0	0	0	0	1	-0.5dB
0	1	0	0	0	0	1	0	-1.0dB
0	1	0	0	0	0	1	1	-1.5dB
0	1	0	0	0	1	0	0	-2.0dB
0	1	0	0	0	1	0	1	-2.5dB
0	1	0	0	0	1	1	0	-3.0dB
0	1	0	0	0	1	1	1	-3.5dB
0	1	0	0	1	0	0	0	-4.0dB
0	1	0	0	1	0	0	1	-4.5dB
0	1	0	0	1	0	1	0	-5.0dB
0	1	0	0	1	0	1	1	-5.5dB
0	1	0	0	1	1	0	0	-6.0dB
0	1	0	0	1	1	0	1	-6.5dB
0	1	0	0	1	1	1	0	-7.0dB
0	1	0	0	1	1	1	1	-7.5dB
0	1	0	1	0	0	0	0	-8.0dB
0	1	0	1	0	0	0	1	-8.5dB
0	1	0	1	0	0	1	0	-9.0dB
0	1	0	1	0	0	1	1	-9.5dB
0	1	0	1	0	1	0	0	-10.0dB
0	1	0	1	0	1	0	1	-10.5dB
0	1	0	1	0	1	1	0	-11.0dB
0	1	0	1	0	1	1	1	-11.5dB
0	1	0	1	1	0	0	0	-12.0dB
0	1	0	1	1	0	0	1	-12.5dB
0	1	0	1	1	0	1	0	-13.0dB
0	1	0	1	1	0	1	1	-13.5dB
0	1	0	1	1	1	0	0	-14.0dB
0	1	0	1	1	1	0	1	-14.5dB
0	1	0	1	1	1	1	0	-15.0dB
0	1	0	1	1	1	1	1	-15.5dB
0	1	1	0	0	0	0	0	-16.0dB
0	1	1	0	0	0	0	1	-16.5dB
0	1	1	0	0	0	1	0	-17.0dB
0	1	1	0	0	0	1	1	-17.5dB
0	1	1	0	0	1	0	0	-18.0dB
0	1	1	0	0	1	0	1	-18.5dB
0	1	1	0	0	1	1	0	-19.0dB
0	1	1	0	0	1	1	1	-19.5dB
0	1	1	0	1	0	0	0	-20.0dB
0	1	1	0	1	0	0	1	-20.5dB
0	1	1	0	1	0	1	0	-21.0dB

< Volume Control Data >

DATA								Setting
D15	D14	D13	D12	D11	D10	D9	D8	
0	1	1	0	1	0	1	1	-21.5dB
0	1	1	0	1	1	0	0	-22.0dB
0	1	1	0	1	1	0	1	-22.5dB
0	1	1	0	1	1	1	0	-23.0dB
0	1	1	0	1	1	1	1	-23.5dB
0	1	1	1	0	0	0	0	-24.0dB
0	1	1	1	0	0	0	1	-24.5dB
0	1	1	1	0	0	1	0	-25.0dB
0	1	1	1	0	0	1	1	-25.5dB
0	1	1	1	0	1	0	0	-26.0dB
0	1	1	1	0	1	0	1	-26.5dB
0	1	1	1	0	1	1	0	-27.0dB
0	1	1	1	0	1	1	1	-27.5dB
0	1	1	1	1	0	0	0	-28.0dB
0	1	1	1	1	0	0	1	-28.5dB
0	1	1	1	1	0	1	0	-29.0dB
0	1	1	1	1	0	1	1	-29.5dB
0	1	1	1	1	1	0	0	-30.0dB
0	1	1	1	1	1	0	1	-30.5dB
0	1	1	1	1	1	1	0	-31.0dB
0	1	1	1	1	1	1	1	-31.5dB
1	0	0	0	0	0	0	0	-32.0dB
1	0	0	0	0	0	0	1	-32.5dB
1	0	0	0	0	0	1	0	-33.0dB
1	0	0	0	0	0	1	1	-33.5dB
1	0	0	0	0	1	0	0	-34.0dB
1	0	0	0	0	1	0	1	-34.5dB
1	0	0	0	0	1	1	0	-35.0dB
1	0	0	0	0	1	1	1	-35.5dB
1	0	0	0	1	0	0	0	-36.0dB
1	0	0	0	1	0	0	1	-36.5dB
1	0	0	0	1	0	1	0	-37.0dB
1	0	0	0	1	0	1	1	-37.5dB
1	0	0	0	1	1	0	0	-38.0dB
1	0	0	0	1	1	0	1	-38.5dB
1	0	0	0	1	1	1	0	-39.0dB
1	0	0	0	1	1	1	1	-39.5dB
1	0	0	1	0	0	0	0	-40.0dB
1	0	0	1	0	0	0	1	-40.5dB
1	0	0	1	0	0	1	0	-41.0dB
1	0	0	1	0	0	1	1	-41.5dB
1	0	0	1	0	1	0	0	-42.0dB
1	0	0	1	0	1	0	1	-42.5dB
1	0	0	1	0	1	1	0	-43.0dB
1	0	0	1	0	1	1	1	-43.5dB
1	0	0	1	1	0	0	0	-44.0dB
1	0	0	1	1	0	0	1	-44.5dB
1	0	0	1	1	0	1	0	-45.0dB
1	0	0	1	1	0	1	1	-45.5dB
1	0	0	1	1	1	0	0	-46.0dB
1	0	0	1	1	1	0	1	-46.5dB
1	0	0	1	1	1	1	0	-47.0dB
1	0	0	1	1	1	1	1	-47.5dB
1	0	1	0	0	0	0	0	-48.0dB
1	0	1	0	0	0	0	1	-48.5dB
1	0	1	0	0	0	1	0	-49.0dB
1	0	1	0	0	0	1	1	-49.5dB
1	0	1	0	0	1	0	0	-50.0dB

< Volume Control Data >

DATA								Setting
D15	D14	D13	D12	D11	D10	D9	D8	
1	0	1	0	0	1	0	1	-50.5dB
1	0	1	0	0	1	1	0	-51.0dB
1	0	1	0	0	1	1	1	-51.5dB
1	0	1	0	1	0	0	0	-52.0dB
1	0	1	0	1	0	0	1	-52.5dB
1	0	1	0	1	0	1	0	-53.0dB
1	0	1	0	1	0	1	1	-53.5dB
1	0	1	0	1	1	0	0	-54.0dB
1	0	1	0	1	1	0	1	-54.5dB
1	0	1	0	1	1	1	0	-55.0dB
1	0	1	0	1	1	1	1	-55.5dB
1	0	1	1	0	0	0	0	-56.0dB
1	0	1	1	0	0	0	1	-56.5dB
1	0	1	1	0	0	1	0	-57.0dB
1	0	1	1	0	0	1	1	-57.5dB
1	0	1	1	0	1	0	0	-58.0dB
1	0	1	1	0	1	0	1	-58.5dB
1	0	1	1	0	1	1	0	-59.0dB
1	0	1	1	0	1	1	1	-59.5dB
1	0	1	1	1	0	0	0	-60.0dB
1	0	1	1	1	0	0	1	-60.5dB
1	0	1	1	1	0	1	0	-61.0dB
1	0	1	1	1	0	1	1	-61.5dB
1	0	1	1	1	1	0	0	-62.0dB
1	0	1	1	1	1	0	1	-62.5dB
1	0	1	1	1	1	1	0	-63.0dB
1	0	1	1	1	1	1	1	-63.5dB
1	1	0	0	0	0	0	0	-64.0dB
1	1	0	0	0	0	0	1	-64.5dB
1	1	0	0	0	0	1	0	-65.0dB
1	1	0	0	0	0	1	1	-65.5dB
1	1	0	0	0	1	0	0	-66.0dB
1	1	0	0	0	1	0	1	-66.5dB
1	1	0	0	0	1	1	0	-67.0dB
1	1	0	0	0	1	1	1	-67.5dB
1	1	0	0	1	0	0	0	-68.0dB
1	1	0	0	1	0	0	1	-68.5dB
1	1	0	0	1	0	1	0	-69.0dB
1	1	0	0	1	0	1	1	-69.5dB
1	1	0	0	1	1	0	0	-70.0dB
1	1	0	0	1	1	0	1	-70.5dB
1	1	0	0	1	1	1	0	-71.0dB
1	1	0	0	1	1	1	1	-71.5dB
1	1	0	1	0	0	0	0	-72.0dB
1	1	0	1	0	0	0	1	-72.5dB
1	1	0	1	0	0	1	0	-73.0dB
1	1	0	1	0	0	1	1	-73.5dB
1	1	0	1	0	1	0	0	-74.0dB
1	1	0	1	0	1	0	1	-74.5dB
1	1	0	1	0	1	1	0	-75.0dB
1	1	0	1	0	1	1	1	-75.5dB
1	1	0	1	1	0	0	0	-76.0dB
1	1	0	1	1	0	0	1	-76.5dB
1	1	0	1	1	0	1	0	-77.0dB
1	1	0	1	1	0	1	1	-77.5dB
1	1	0	1	1	1	0	0	-78.0dB
1	1	0	1	1	1	0	1	-78.5dB
1	1	0	1	1	1	1	0	-79.0dB

< Volume Control Data >

DATA								Setting
D15	D14	D13	D12	D11	D10	D9	D8	
1	1	0	1	1	1	1	1	-79.5dB
1	1	1	0	0	0	0	0	-80.0dB
1	1	1	0	0	0	0	1	-80.5dB
1	1	1	0	0	0	1	0	-81.0dB
1	1	1	0	0	0	1	1	-81.5dB
1	1	1	0	0	1	0	0	-82.0dB
1	1	1	0	0	1	0	1	-82.5dB
1	1	1	0	0	1	1	0	-83.0dB
1	1	1	0	0	1	1	1	-83.5dB
1	1	1	0	1	0	0	0	-84.0dB
1	1	1	0	1	0	0	1	-84.5dB
1	1	1	0	1	0	1	0	-85.0dB
1	1	1	0	1	0	1	1	-85.5dB
1	1	1	0	1	1	0	0	-86.0dB
1	1	1	0	1	1	0	1	-86.5dB
1	1	1	0	1	1	1	0	-87.0dB
1	1	1	0	1	1	1	1	-87.5dB
1	1	1	1	0	0	0	0	-88.0dB
1	1	1	1	0	0	0	1	-88.5dB
1	1	1	1	0	0	1	0	-89.0dB
1	1	1	1	0	0	1	1	-89.5dB
1	1	1	1	0	1	0	0	-90.0dB
1	1	1	1	0	1	0	1	-90.5dB
1	1	1	1	0	1	1	0	-91.0dB
1	1	1	1	0	1	1	1	-91.5dB
1	1	1	1	1	0	0	0	-92.0dB
1	1	1	1	1	0	0	1	-92.5dB
1	1	1	1	1	0	1	0	-93.0dB
1	1	1	1	1	0	1	1	-93.5dB
1	1	1	1	1	1	0	0	-94.0dB
1	1	1	1	1	1	0	1	-94.5dB
1	1	1	1	1	1	1	0	-95.0dB
1	1	1	1	1	1	1	1	Mute ^(*)

^(*):initial setting

◆**Input Selector** : Selector for the stereo inputs

D15	D14	D13	D12	D11	D10	D9	D8	D7	D6	D5	D4	D3	D2	D1	D0
Don't Care			Input selector			Don't Care	Don't Care	0	0	1	0	*	*	*	*

< Input Selector Data >

Data			Setting
D12	D11	D10	
0	0	0	Mute ^(*)
0	0	1	Input1
0	1	0	Input2
0	1	1	Input3
1	0	0	Input4

^(*)initial setting

◆**TC/B** : Treble Cut / Boost
Tone Control Treble : Treble Gain
TSW : Tone Control By-pass Switch

D15	D14	D13	D12	D11	D10	D9	D8	D7	D6	D5	D4	D3	D2	D1	D0
TC/B	Treble control				TSW	Don't Care	Don't Care	0	0	1	1	*	*	*	*

< TC/B : Treble Cut / Boost >

D15	Setting
0	Cut ^(*)
1	Boost

< Tone Control Treble : Treble Gain >

Data				Cut	Boost
D14	D13	D12	D11		
0	0	0	0	0dB ^(*)	0dB
0	0	0	1	-1dB	1dB
0	0	1	0	-2dB	2dB
0	0	1	1	-3dB	3dB
0	1	0	0	-4dB	4dB
0	1	0	1	-5dB	5dB
0	1	1	0	-6dB	6dB
0	1	1	1	-7dB	7dB
1	0	0	0	-8dB	8dB
1	0	0	1	-9dB	9dB
1	0	1	0	-10dB	10dB

< TSW : Tone Control By-pass Switch >

D10	Setting
0	Tone Control OFF ^(*)
1	Tone Control ON

^(*)Initial Setting

◆BC/B : Bass Cut / Boost
 Tone Control Bass : Bass Gain

D15	D14	D13	D12	D11	D10	D9	D8	D7	D6	D5	D4	D3	D2	D1	D0
BC/B	Bass control				Don't Care	Don't Care	Don't Care	0	1	0	0	*	*	*	*

< BC/B : Bass Cut / Boost >

D15	Setting
0	Cut ^(*)
1	Boost

<Tone Control Bass : Bass Gain >

Data				Cut	Boost
D14	D13	D12	D11		
0	0	0	0	0dB ^(*)	0dB
0	0	0	1	-1dB	1dB
0	0	1	0	-2dB	2dB
0	0	1	1	-3dB	3dB
0	1	0	0	-4dB	4dB
0	1	0	1	-5dB	5dB
0	1	1	0	-6dB	6dB
0	1	1	1	-7dB	7dB
1	0	0	0	-8dB	8dB
1	0	0	1	-9dB	9dB
1	0	1	0	-10dB	10dB

^(*)Initial Setting

TYPICAL CHARACTERISTICS

ICC vs Supply Voltage

No signal

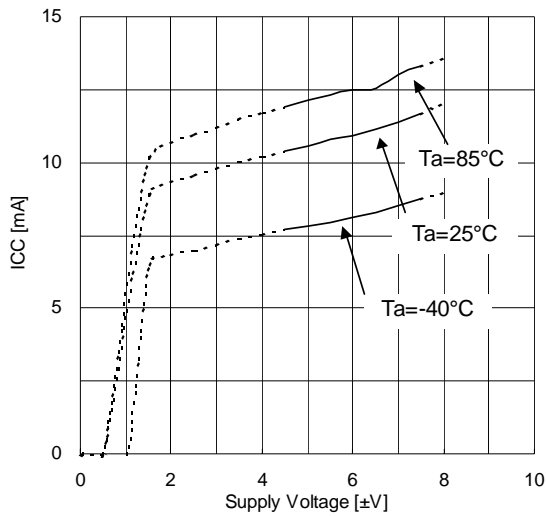

IEE vs Supply Voltage

No signal

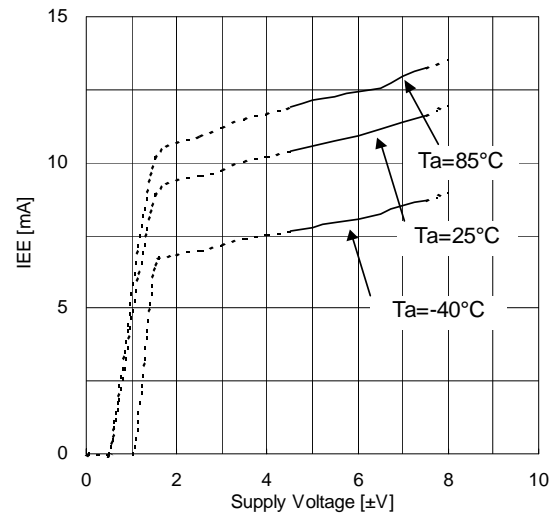

ICC vs Ambient Temperature

No signal

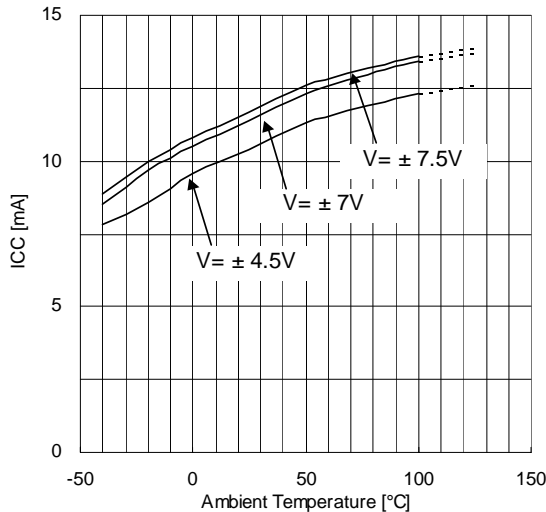

IEE vs Ambient Temperature

No signal

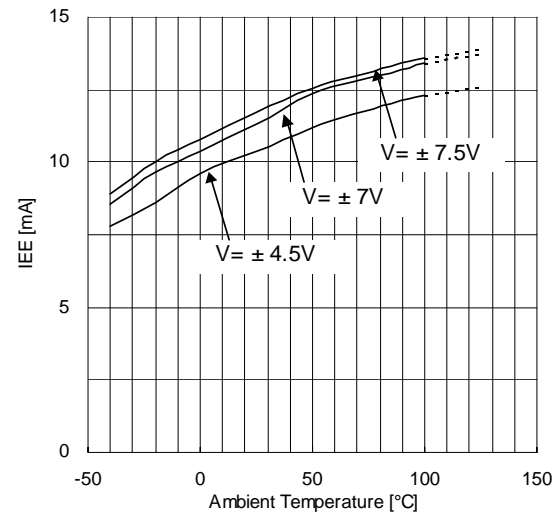

Maximum Output Voltage vs Frequency

V=±7V, THD=1%, VOL=0dB, I/O:INA1-Aout,
TONE=OFF, I/O: INA1-Aout

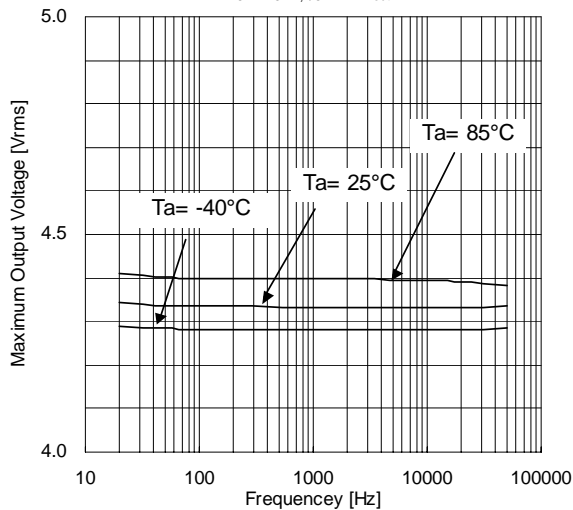

Maximum Output Voltage vs Frequency

V=±7V, THD=1%, VOL=0dB, I/O:INA1-Aout,
TONE=ON, I/O: INA1-Aout

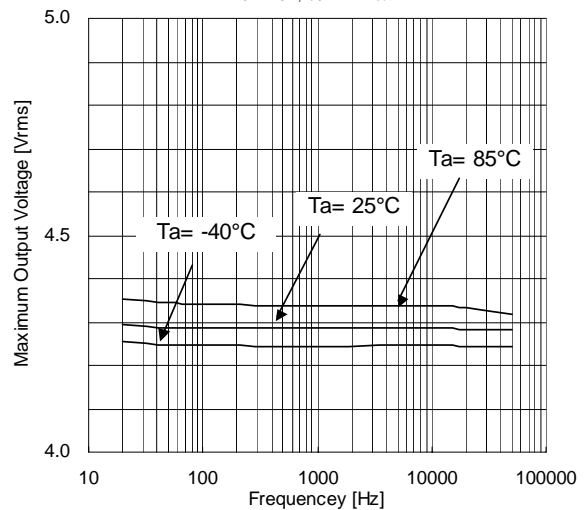

TYPICAL CHARACTERISTICS

Maximum Output Voltage vs Ambient Temperature
Temperature

V=±7V, THD=1%, VOL=0dB, I/O: INA1-Aout,
TONE=OFF, I/O: INA1-Aout

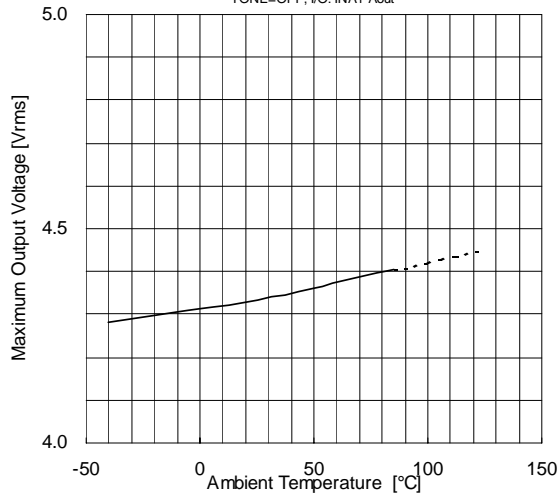

Maximum Output Voltage vs Ambient Temperature
Temperature

V=±7V, THD=1%, VOL=0dB, I/O: INA1-Aout,
TONE=ON, I/O: INA1-Aout

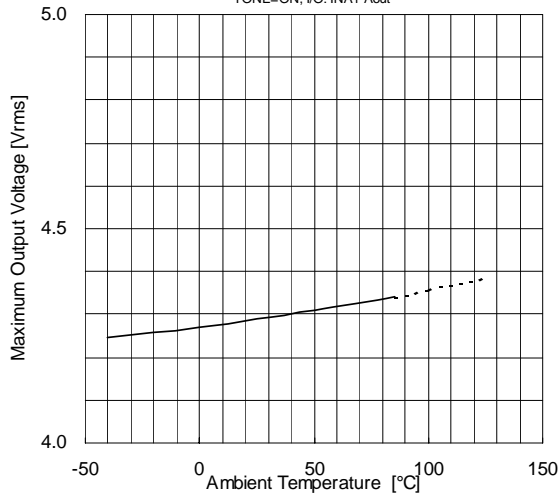

Volume Gain Output vs Volume Setting

V=±7V, Vin=2Vrms, f=1kHz, Bandpass,
I/O: INA1-Aout, TONE=OFF

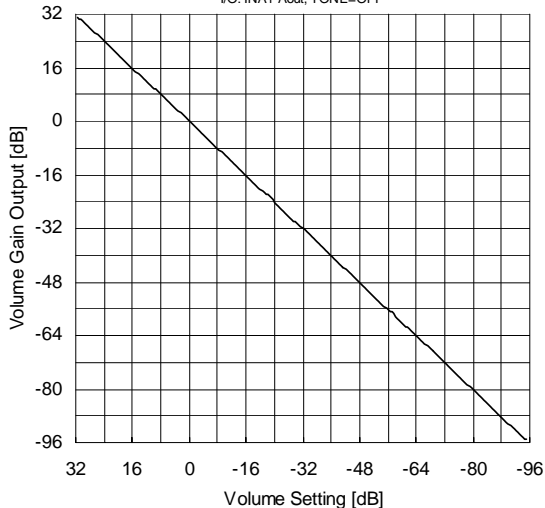

Volume Gain Output vs Volume Setting

V=±7V, Vin=2Vrms, f=1kHz, Bandpass,
I/O: INA1-Aout, TONE=ON

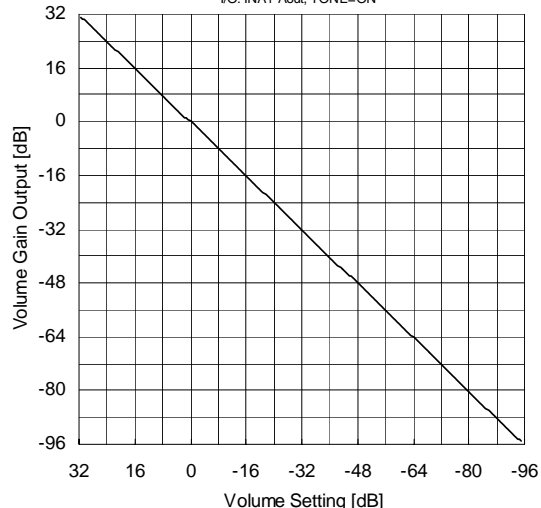

Volume Gain output vs Frequency

V=±7V, Vin=2Vrms (VOL=0, -50, -95dB, Mute), Vin=0.1Vrms (VOL=+15, +30dB),
Bandpass, I/O: INA1-Aout, TONE=OFF

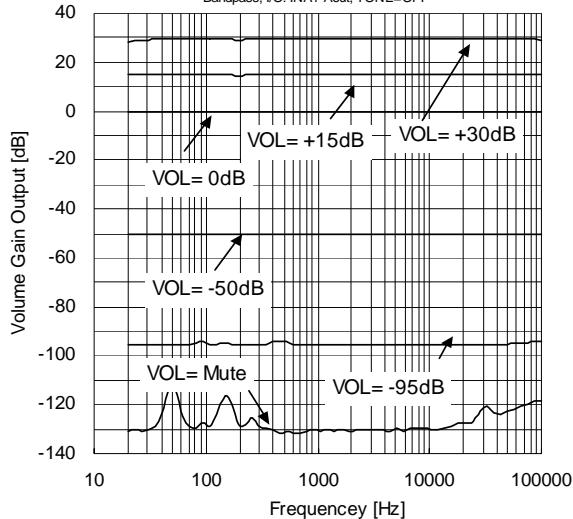

Volume Gain output vs Frequency

V=±7V, Vin=2Vrms (VOL=0, -50, -95dB, Mute), Vin=0.1Vrms (VOL=+15, +30dB),
Bandpass, I/O: INA1-Aout, TONE=ON

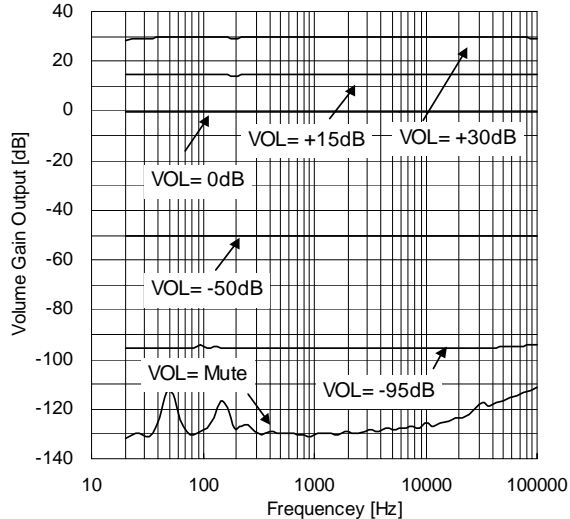

TYPICAL CHARACTERISTICS

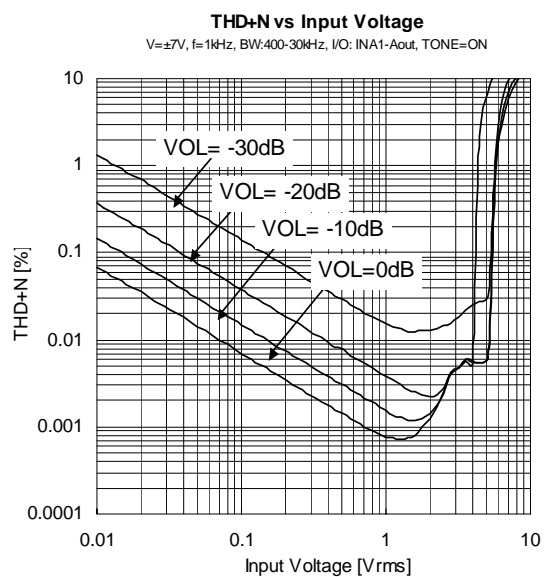
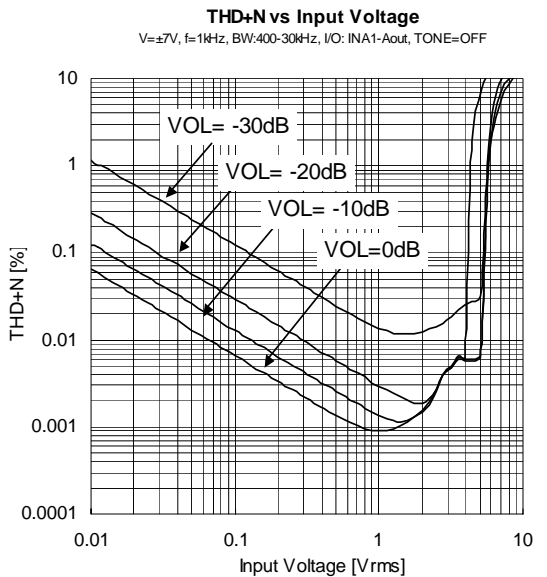
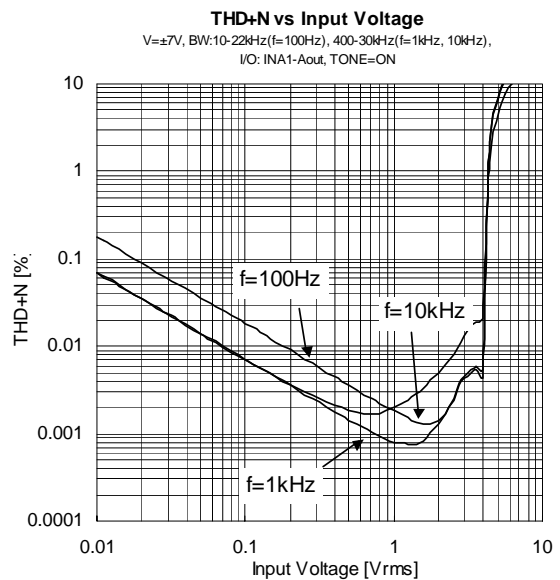
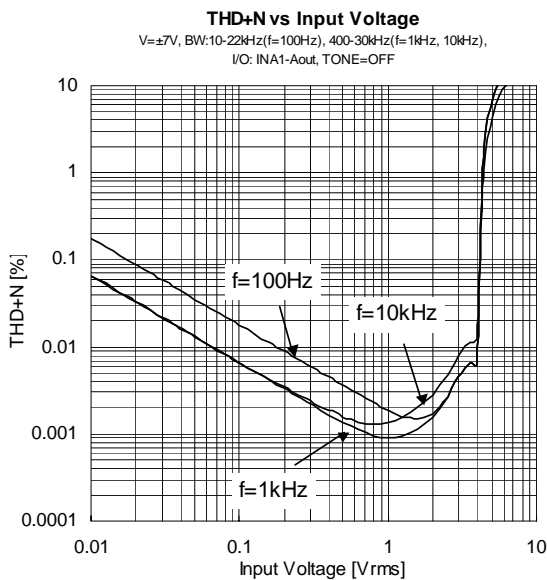
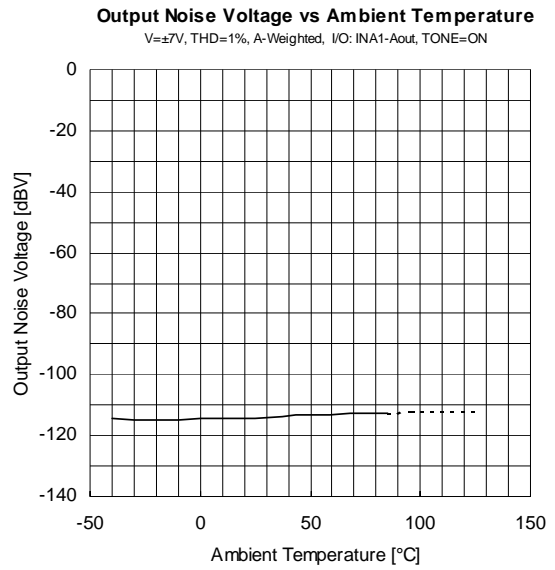
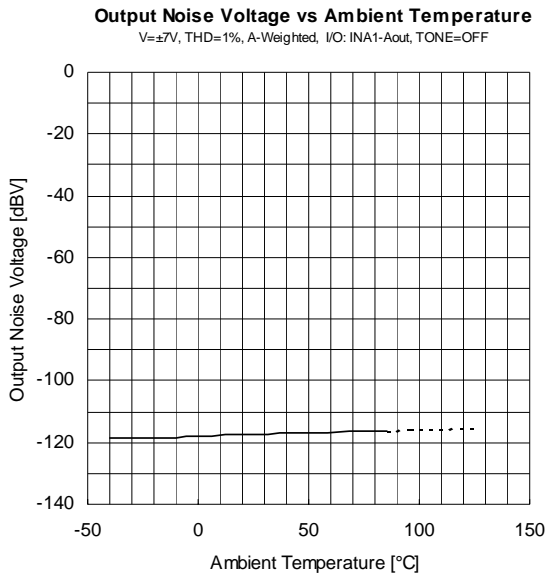

TYPICAL CHARACTERISTICS

THD+N vs Frequency

$V = \pm 7V$, $V_{in} = 1V_{rms}$, $VOL = 0dB$, $BW: 10-80kHz$, $I/O: INA1-Aout$

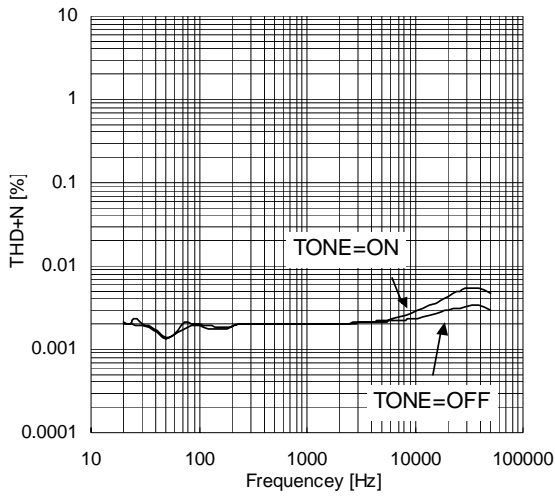

THD+N vs Frequency

$V = \pm 7V$, $V_{in} = 2V_{rms}$, $VOL = 0dB$, $BW: 10-80kHz$, $I/O: INA1-Aout$

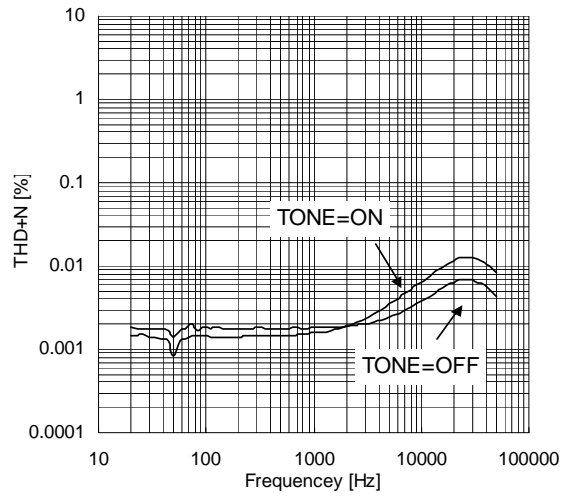

THD+N vs Ambient Temperature

$V = \pm 7V$, $f = 1kHz$, $BW: 400-30kHz$, $I/O: INA1-Aout$, $TONE = OFF$

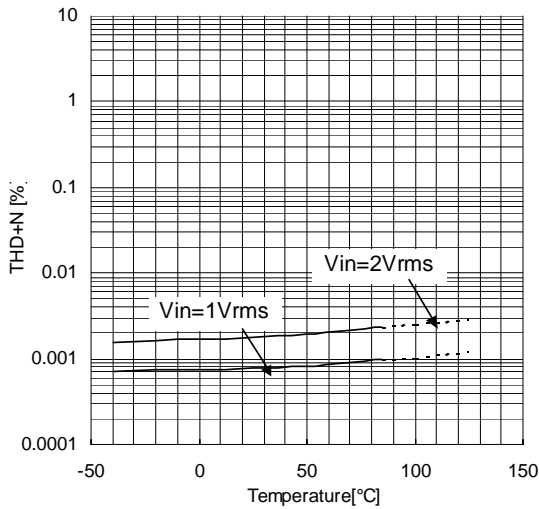

THD+N vs Ambient Temperature

$V = \pm 7V$, $f = 1kHz$, $BW: 400-30kHz$, $I/O: INA1-Aout$, $TONE = ON$

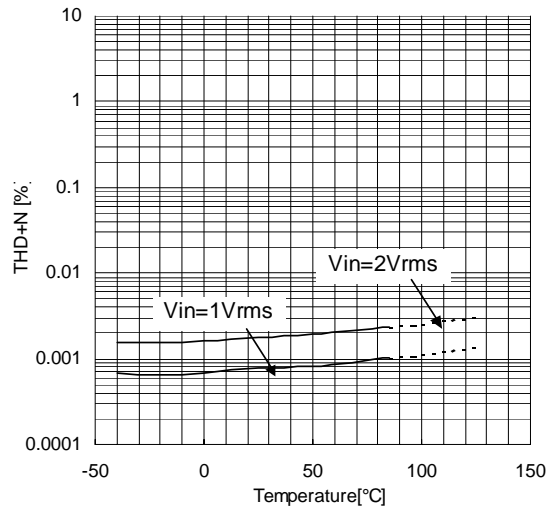

Channel Separation vs Frequency

$V = \pm 7V$, $V_{in} = 2V_{rms}$, $VOL = 0dB$, $BW: 10-80kHz$, $I/O: INB1-Aout$, $TONE = OFF$

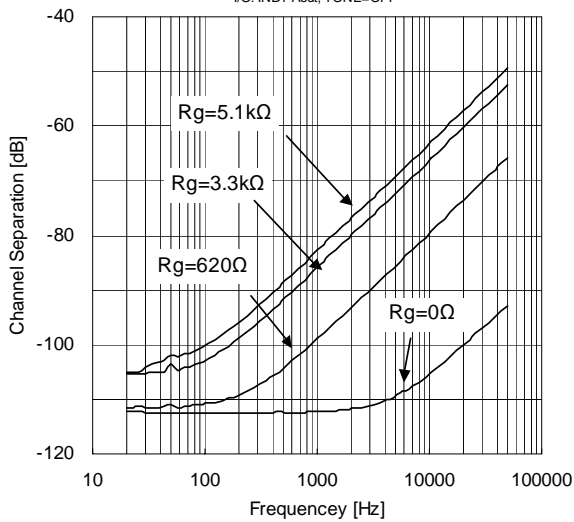

Channel Separation vs Frequency

$V = \pm 7V$, $V_{in} = 2V_{rms}$, $VOL = 0dB$, $BW: 10-80kHz$, $I/O: INB1-Aout$, $TONE = ON$

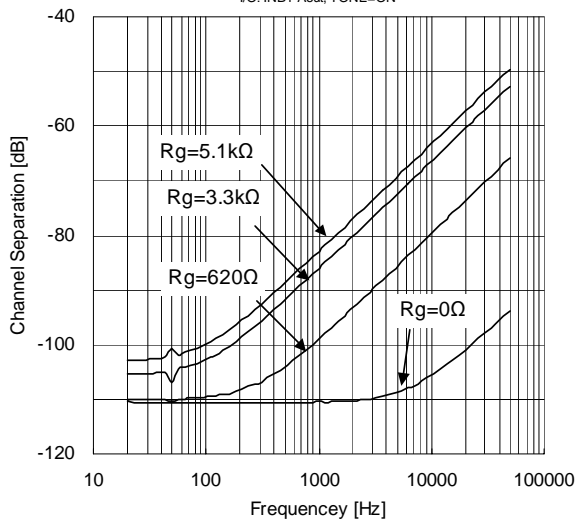

TYPICAL CHARACTERISTICS

Cross Talk vs Frequency

$V = \pm 7V$, $V_{in} = 2V_{rms}$, $VOL = 0dB$, $BW: 10-80kHz$,
I/O: INA1,3,4-Aout, Select Channel:2ch, TONE=OFF

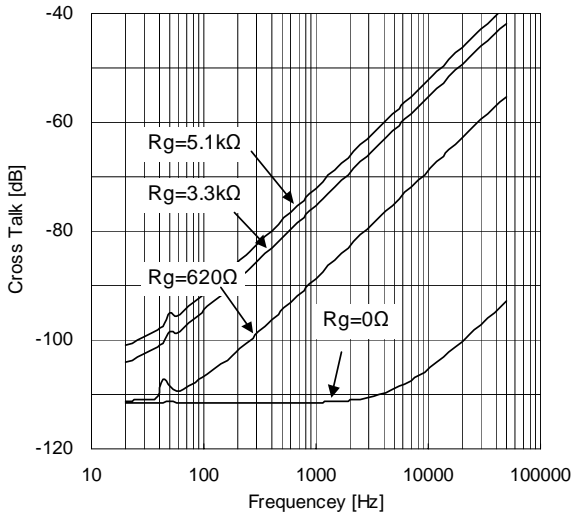

Cross Talk vs Frequency

$V = \pm 7V$, $V_{in} = 2V_{rms}$, $VOL = 0dB$, $BW: 10-80kHz$,
I/O: INA1,3,4-Aout, Select Channel:2ch, TONE=ON

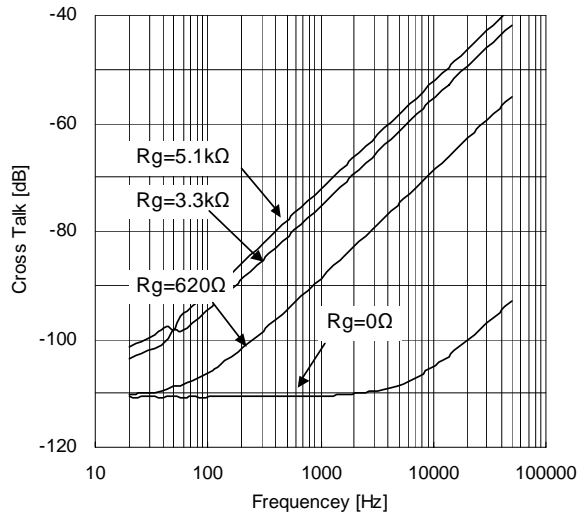

Cross Talk vs Frequency

$V = \pm 7V$, $V_{in} = 2V_{rms}$, $VOL = 0dB$, $BW: 10-80kHz$,
I/O: INA1-Aout, Select Channel:2ch, TONE=OFF

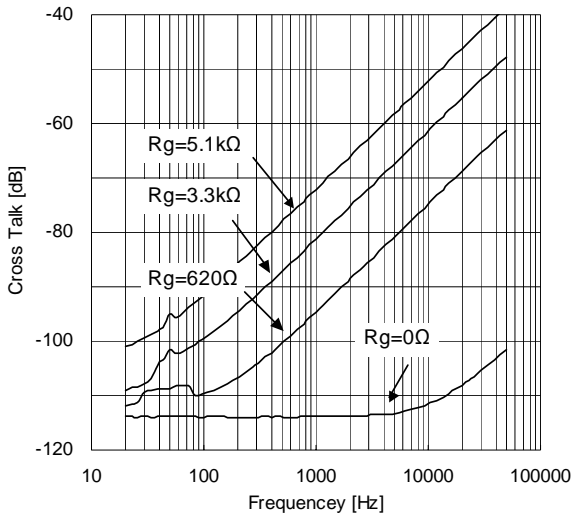

Cross Talk vs Frequency

$V = \pm 7V$, $V_{in} = 2V_{rms}$, $VOL = 0dB$, $BW: 10-80kHz$,
I/O: INA1-Aout, Select Channel:2ch, TONE=ON

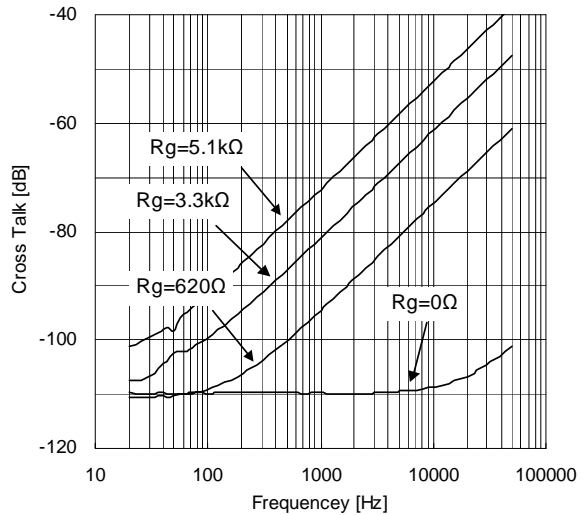

Tone Control (BASS) vs Frequency

$V = \pm 7V$, $V_{in} = 100mV_{rms}$, I/O: INA1-Aout, TONE=ON, BASS=0dB

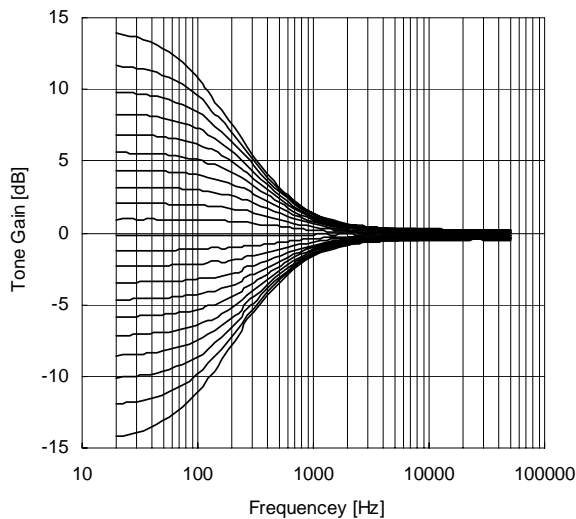

Tone Control (TREBLE) vs Frequency

$V = \pm 7V$, $V_{in} = 100mV_{rms}$, I/O: INA1-Aout, TONE=ON, BASS=0dB

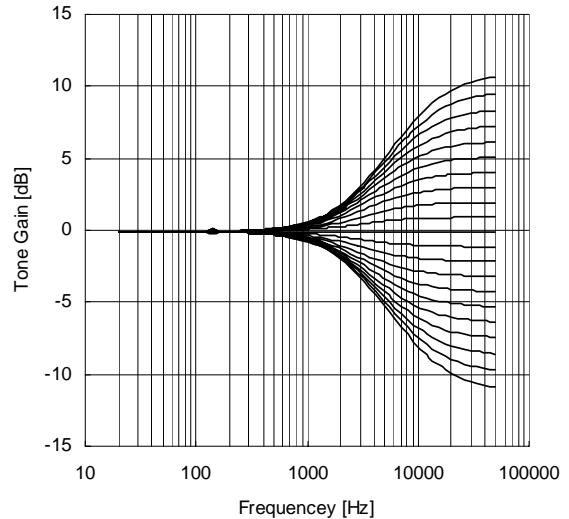

TYPICAL CHARACTERISTICS

TONE Control(TREBLE) vs Ambient Temperature

$V_s = \pm 7V$, $V_{in} = 100mV$, I/O: INA1-Aout

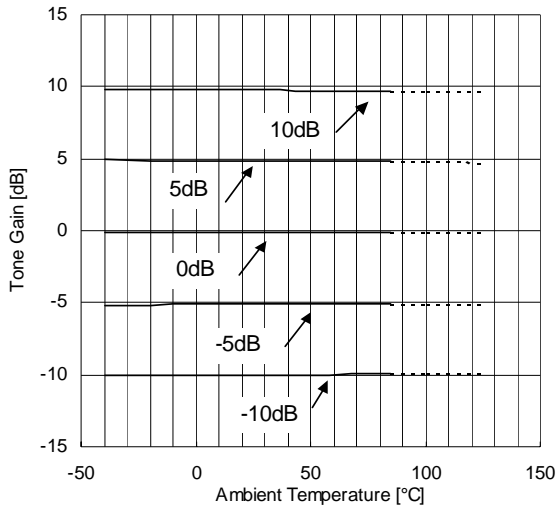

TONE Control(BASS) vs Ambient Temperature

$V_s = \pm 7V$, $V_{in} = 100mV$, I/O: INA1-Aout

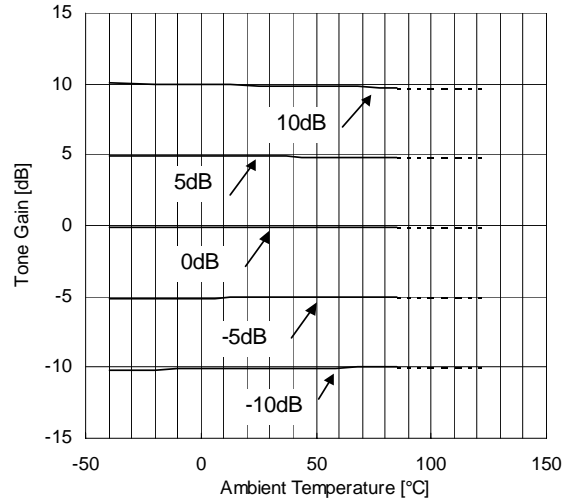

Tone Control (TREBLE) vs Frequency

$V_s = \pm 7V$, $V_{in} = 100mV_{rms}$, I/O: INA1-Aout, TONE=ON, BASS=0dB

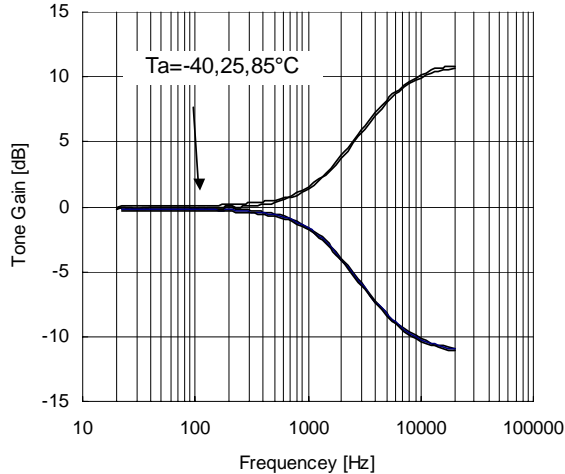

Tone Control (BASS) vs Frequency

$V_s = \pm 7V$, $V_{in} = 100mV_{rms}$, I/O: INA1-Aout, TONE=ON, TREBLE=0dB

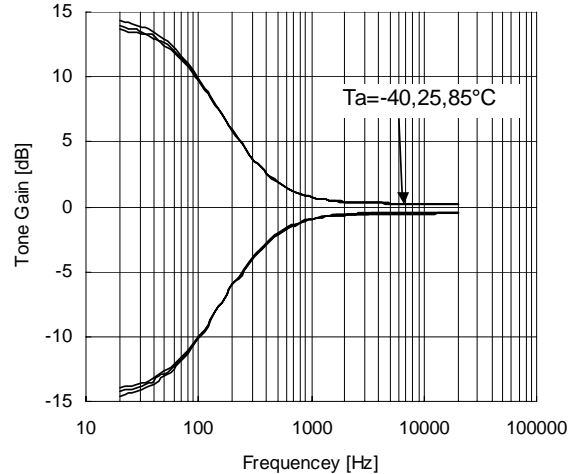

Output Voltage vs Load Resistance

$V_s = \pm 7V$, $f = 1kHz$, $V_{in} = 4.2V_{rms}$, $V_{OL} = 0dB$,
I/O: INA1-Aout / INB1-Bout, TONE=OFF

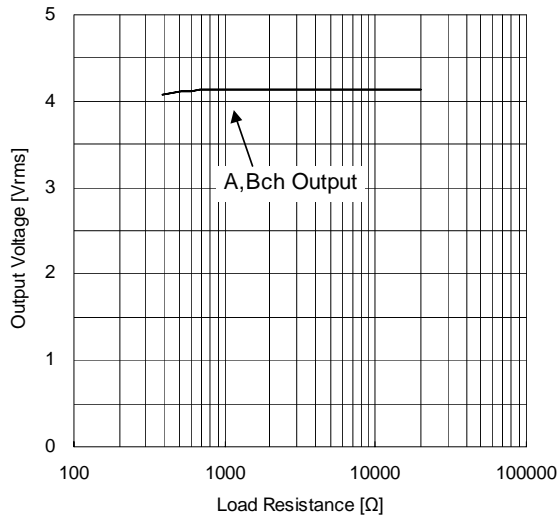

Output Voltage vs Load Resistance

$V_s = \pm 7V$, $f = 1kHz$, $V_{in} = 4.2V_{rms}$, $V_{OL} = 0dB$,
I/O: INA1-Aout / INB1-Bout, TONE=ON

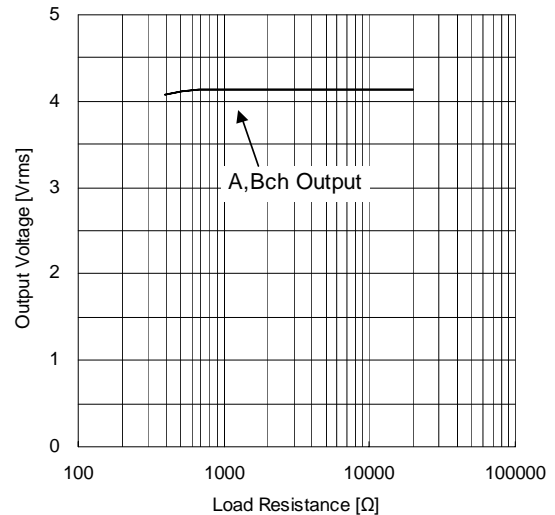

[CAUTION]

The specifications on this databook are only given for information , without any guarantee as regards either mistakes or omissions. The application circuits in this databook are described only to show representative usages of the product and not intended for the guarantee or permission of any right including the industrial rights.