

JRC SAW Resonators

NJR
NEWS

2003

37

October 28, 2003

NSVS803 & Others

JRC SAW Resonator

This newsletter talks about JRC's SAW Resonators and the NSVS803.

SAW: Surface Acoustic Wave

STW: Surface Transverse Wave

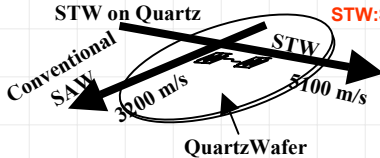

JRC SAW Resonators Product Offering

Frequency (MHz)	Part Number	Mode	Package
433.92	NSVS803	SAW	3.2x2.5
311.5	NSVS926	STW	3.2x2.5
315.1	NSVS927	STW	3.2x2.5
304.4	NSVS973	STW	3.2x2.5

Features

- High Performance
- Low Insertion Loss
- Low power
- Small-sized package using Flip-chip Technology
- Surface Mount Device (SMD) (3.2x2.5x1.1mm³)
- Low Aging
- Custom/Semi-custom Design Capabilities

Applications

- Remote Keyless Entry (RKE)

Block Diagram

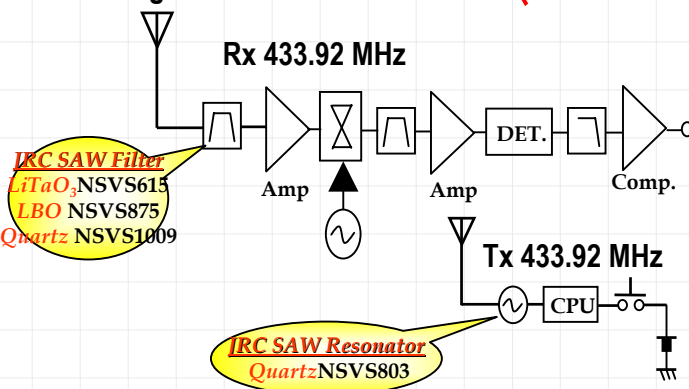

NOW Available!

Electric Characteristic for NSVS803

	Sym	Min	Typical	Max.	Unit
Center frequency [MHz]	f_0	-	433.92	-	MHz
Tolerance from f_0	-	-	150	-	ppm
Insertion Loss	IL	-	1.8	-	dB
Unloaded Quality Factor	Q_u	-	11000	-	-
Turn Over Temperature	T_0	-	22	-	°C
Frequency Temperature Coefficient	FTC	-	-0.037	-	ppm/°C

SAW Resonator Application Characteristics

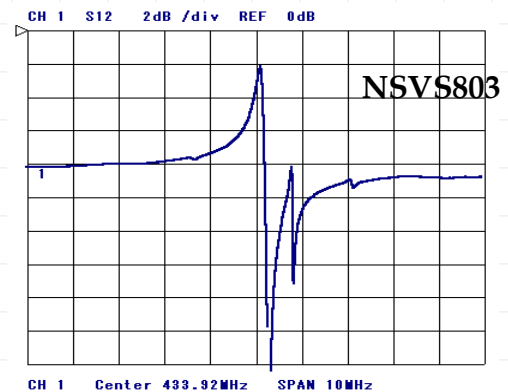

Equivalent Circuit

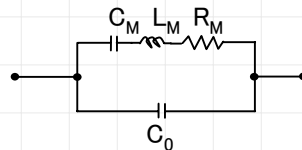

	Spec.	Typical	Unit
R_M	-	18.98	ohm
L_M	-	77.02	uH
C_M	-	1.74	fF
C_0	-	1.95	fF

Temperature Characteristic

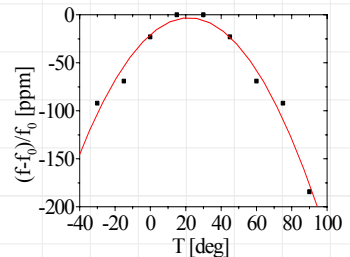

NJR CORPORATION

A SUBSIDIARY OF NEW JAPAN RADIO COMPANY, LTD.

198 Stauffer Blvd. San Jose, CA 95125

NJR CORPORATION offers Bipolar ICs, CMOS ICs, BiCMOS ICs and GaAs MMICs as well as Saw filters, covering North and South America to provide technical assistance and quick delivery for achieving customer satisfactions. For further information, please contact:

PHONE : (408) - 995-6200 or WWW.NJR.COM

The World's Best Source for High Quality ICs using Bipolar, CMOS, BiCMOS, and GaAs Technologies as well as Saw Filters